



Dental Treatment Unit

Signo T500

Operation panel

Operation Instructions



Thinking ahead. Focused on life.

Thank you very much for purchasing the Signo T500.

Be sure to read these operation instructions completely and observe the method of use and precautions before use in order to fully utilize the functions of this equipment, to use it effectively, and to use it safely and without harm to people.

Read this operation instructions carefully before use. Keep the operation instructions close to this unit for future reference.

■ Trademarks and registered trademarks

The names of companies, products, services etc. listed in these operation instructions are the trademarks or registered trademarks of the respective company.

Contents

| | |
|--|----|
| ■ Introduction | 6 |
| ■ 1 Installation | 8 |
| 1.1 Installation | 8 |
| 1.2 Preparation | 8 |
| 1.3 Connection of Instruments | 9 |
| 1.4 Installation of Filters in Each Part | 9 |
| ■ 2 Part Names | 10 |
| 2.1 Chair Type | 10 |
| 2.2 Tray Type | 12 |
| 2.3 Operation Panel | 14 |
| 2.4 Foot Control | 15 |
| 2.5 Accessories | 16 |

■ 3 Actions Before and After Use 17

| | |
|---|----|
| 3.1 Preparation Before Use..... | 17 |
| 3.1.1 Water/Air Supply and Main Switch..... | 17 |
| 3.2 Interruption/Completion of Use..... | 18 |
| 3.3 Storage..... | 19 |

■ 4 Method of Operation 20

| | |
|---|----|
| 4.1 Precautions When Operating the Chair..... | 21 |
| 4.1.1 Precautions When Operating the Chair..... | 21 |
| 4.1.2 Safety Switch..... | 22 |
| 4.2 Operation Panel..... | 24 |
| 4.2.1 Operation Switch..... | 24 |
| 4.3 Chair..... | 28 |
| 4.3.1 Manual Chair Operation..... | 28 |
| 4.3.2 Automatic Movement of Chair..... | 29 |
| 4.3.3 Cordless Foot Control | 33 |
| 4.3.4 Headrest Height and Angle Adjustment..... | 34 |
| 4.3.5 Backrest Height Adjustment..... | 36 |
| 4.3.6 Armrest..... | 37 |
| 4.4 Tray..... | 38 |
| 4.4.1 Tray..... | 38 |
| 4.4.2 Over-the-Patient Tray Type/Floor-mounted Tray Type..... | 40 |
| 4.4.3 Cart..... | 42 |
| 4.4.4 Auxiliary Tray..... | 43 |
| 4.5 Instrument Holder..... | 44 |
| 4.5.1 Doctor-side Holder..... | 44 |
| 4.5.2 Assistant-side Holder..... | 45 |
| 4.6 Instruments..... | 48 |
| 4.6.1 Water Tank..... | 48 |
| 4.6.2 Water Supply Rate Adjustment..... | 49 |
| 4.6.3 Foot Control Operation (extended function) | 50 |
| 4.6.4 Air Turbine Handpiece..... | 51 |
| 4.6.5 Micromotor..... | 54 |
| 4.6.6 Threeway Syringe..... | 57 |

| | |
|---|----|
| 4.6.7 Vacuum Syringe | 61 |
| 4.6.8 Saliva Ejector | 63 |
| 4.6.9 Ultrasonic Scaler (Newtron) | 64 |
| 4.6.10 Ultrasonic Scaler (Solfy) | 67 |
| 4.7 Unit | 70 |
| 4.7.1 Part Names | 70 |
| 4.7.2 Warmer | 72 |
| 4.7.3 One-touch Connectors (water supply/air supply) | 73 |
| 4.8 Basin | 75 |
| 4.8.1 Basic Operation | 75 |
| 4.8.2 Cup Water Supply | 77 |
| 4.9 Operating Light | 78 |
| 4.9.1 Basic Operation | 78 |
| 4.9.2 Setting | 80 |
| 4.10 Other Settings | 81 |
| 4.10.1 Countdown Timer | 81 |
| 4.10.2 Display while Instruments are in their Holders | 83 |
| 4.10.3 Common Settings | 86 |
| 4.10.4 Individual User Settings | 89 |

■ 5 Caring for the Unit 98

| | |
|---|-----|
| 5.1 Autoclave Sterilization | 98 |
| 5.1.1 Instrument Sterilization | 99 |
| 5.1.2 Holder Cup Sterilization | 100 |
| 5.1.3 Other Sterilization | 103 |
| 5.2 Wiping with Disinfectant Ethanol | 104 |
| 5.2.1 Instrument Wiping | 104 |
| 5.2.2 Wiping the Leather Seat | 105 |
| 5.2.3 Wiping Other Parts | 106 |
| 5.3 Other Cleaning Methods | 107 |
| 5.4 Everyday Maintenance (before treatment) | 108 |
| 5.4.1 Flushing of Residual Water | 108 |

| | |
|--|-----|
| 5.5 Everyday Maintenance (between patients)..... | 112 |
| 5.5.1 Vacuum System Rinsing..... | 112 |
| 5.5.2 Automatic Rinsing of Vacuum Tank..... | 114 |
| 5.6 Everyday Maintenance (after use)..... | 115 |
| 5.6.1 Cleaning the Vacuum Filter..... | 115 |
| 5.6.2 Cleaning the Basin..... | 116 |
| 5.6.3 Vacuum Syringe Disassembly and Cleaning..... | 118 |
| 5.6.4 Disassembly and Cleaning the Saliva Ejector..... | 120 |
| 5.7 Monthly Maintenance..... | 122 |
| 5.7.1 Cleaning the Water Supply Tank..... | 122 |
| 5.7.2 Checking and Cleaning the Vacuum Tank..... | 123 |
| 5.7.3 Amalgam separator..... | 125 |
| 5.7.4 Spittoon Valve..... | 125 |
| 5.7.5 Cleaning Inside the Drain Trap..... | 126 |
| 5.7.6 Cleaning the Oil Collector..... | 128 |
| 5.8 Annual Maintenance..... | 129 |
| 5.8.1 Sterapore Cartridge Replacement..... | 129 |
| 5.9 Maintenance as Required..... | 133 |
| 5.9.1 Cleaning the Automatic Filler..... | 133 |
| 5.9.2 Cleaning Other Parts..... | 133 |

■ 6 Maintenance and Inspection 134

| | |
|---|-----|
| 6.1 Replacement of Consumable Parts..... | 134 |
| 6.1.1 List of consumable parts..... | 135 |
| 6.1.2 Parts Replacement for Threeway Syringe..... | 137 |
| 6.2 Daily Inspection by the User..... | 138 |
| 6.2.1 Startup Inspection..... | 138 |
| 6.2.2 Shutdown Inspection..... | 138 |
| 6.3 Regular Maintenance Inspection..... | 139 |
| 6.3.1 Maintenance and Inspection by the User..... | 139 |
| 6.3.2 Outsourcing Maintenance and Inspection to a Contractor..... | 140 |
| 6.4 After-sales Service and Contact Information..... | 140 |

| | |
|--|------------|
| 7 If Problems Arise | 141 |
| 7.1 Items to be Checked before Requesting Repair | 141 |
| 7.2 Error Display | 142 |
| 7.3 Fuse | 143 |
| 8 Warranty and Repair | 144 |
| 8.1 Warranty of this Product | 144 |
| 8.2 Warranty Card | 144 |
| 8.3 Repair | 144 |
| 8.3.1 Before Requesting a Repair | 144 |
| 8.3.2 Requesting a Repair | 144 |
| 8.3.3 Spare Part Maintenance Period | 144 |
| 9 Disposal of the Medical Device | 145 |
| 9.1 Disposal of This Product | 145 |
| 10 General Information | 146 |
| 10.1 Specifications | 146 |
| 10.2 Symbols | 147 |
| 10.3 EMC Electromagnetic Compatibility | 148 |
| 10.4 EC DECLARATION OF CONFORMITY | 151 |

Introduction

Attention Customers

Please be to sure receive a full explanation of how to handle each item based on the operation instructions supplied with the product. After confirmation, fill in the Warranty Card with the clinic name and address and telephone number, sign it and hand over a copy to the dealer.

Attention Dealers

After completion of installation, explain how to handle each item to the user based on these operation instructions in order to ensure safety.







After the explanation, ask the doctor to fill in the name of the clinic and address, telephone number, signature on the Warranty Card, then add your own name and hand the card to the doctor. A copy of the warranty card (manufacturing site copy) must be sent to J. MORITA TOKYO MFG. CORP.

Preventing Accidents

Most operation and maintenance problems result from insufficient attention being paid to basic safety precautions and not being able to foresee the possibilities of accidents.

Problems and accidents are best avoided by foreseeing the possibility of danger and operating the unit in accordance with the manufacturer's recommendations. After carefully reading the warnings and precautions on each page, "Contraindications/Prohibitions" and "Precautions for Use (Safety and Hazard Prevention) of Electric Medical Devices", the equipment must be operated with the utmost caution to prevent either damaging the equipment itself or causing bodily injury.

The degrees of harm or damage that may occur when this content is ignored and incorrect use occurs are categorized according to the following.

| List of Safety Symbols | |
|--|---|
|  WARNING | Indicates something that is expected to cause severe bodily injury (death/serious injury etc.) and damage to the equipment if handled incorrectly. |
|  CAUTION | Indicates something that is expected to cause minor injury and damage to the equipment if handled incorrectly. |
| Symbols |  This symbol alerts the user to a warning/precaution. |
| |  This symbol alerts the user to something that is prohibited. |
| |  This symbol alerts the user to instructions and content which must be followed. |
| |  This symbol alerts the user to pay attention to high temperature. |
| |  This symbol alerts the user to a dangerous voltage. |

The user (e.g., healthcare facility, clinic, hospital etc.) is responsible for the management, maintenance, and use of medical devices.

this equipment must only be used by dentists and other legally licensed professionals.





Please do not use this equipment for purposes other than dental practice.

Disclaimer



- Be aware that we cannot assume responsibility for the following (1)-(7).
 - (1) faults/injury resulting from repairs made by personnel not authorized by MORITA,
 - (2) any changes, modifications, or alterations to our products,
 - (3) faults/injury sustained by the use of products or equipment made by other manufacturers if not supplied by MORITA,
 - (4) faults/injury due to maintenance/repairs using spare parts other than genuine parts specified by MORITA,
 - (5) faults/injury due to failure to observe the precautions and follow the methods described in these operation instructions.
 - (6) faults/injury due to ambient conditions deviating from the conditions for use of this equipment such as the power supply and installation environment described in these operation instructions.
 - (7) faults/injury due to natural disasters such as fire, earthquake, flood, lightning etc.
- Attach the handpiece or syringe specified by us to the chair unit and do not use parts other than those specified by us. When attaching/connecting parts other than those specified by us, there is a danger that the part may become disconnected and fly out during use. Be aware that we cannot assume responsibility for faults in our products or injury or health problems if they arise under such circumstances.
- The working life (number of years of use) is 10 years (by self-certification) conditional upon regular maintenance and inspection being carried out after shipment.
- The working life for the safety and maintenance of each part is described in "Safety Note for Users of Dental Treatment Units (Issued by the Japan Dental Machine Manufacturers Association)" supplied with this device. Safety checks, checks on whether functionality has diminished and/or maintenance should be conducted before the end of the working life.
- Always ensure that a supply of tap water is connected to this equipment.

1 Installation



1.1 Installation

|  WARNING | |
|--|--|
|  | <p>Installation of this product should be carried out by a specialist technician (by MORITA CORP. or by a company designated by us). The installation must be in accordance with the supplied installation control standard.</p> <ul style="list-style-type: none"> • There is a danger of accidents and faults due to unforeseen circumstances. |
| | <p>Always ensure that this product is fixed to the floor using an appropriate method (stated in the supplied installation control standard).</p> <ul style="list-style-type: none"> • If not properly fixed, there is danger that the product will topple over and cause an accident and fault. |
|  | <p>Do not use a power supply other than one of the stipulated power supply frequency [Hz], voltage [V], and permissible current [A] (or power consumption). Always ensure that a dedicated power supply circuit is provided for each unit and avoid sharing the power supply with other appliances and avoid a common/branching power supply.</p> <ul style="list-style-type: none"> • There is a danger of accidents and faults such as fire/electric shock etc. |
| | <p>Do not locate the unit where it is likely to get wet or in a location that gets wet.</p> <ul style="list-style-type: none"> • There is a danger that a short circuit or overheating may occur and cause a fault or accident such as fire/electric shock. |
| | <p>Do not install in a location where chemicals are stored or where gas is generated.</p> <ul style="list-style-type: none"> • There is a danger of accidents and faults such as fire/electric shock etc. |
| | <p>Do not position the power cord, ground wire, or foot control cable in a location where damage may easily occur (door, passageway etc.).</p> <ul style="list-style-type: none"> • There is a danger of accidents and faults such as a short circuit/electric shock etc. |
|  CAUTION | |
|  | <p>Do not install the unit in an unstable location, such as on a slope or on a site subject to vibrations or impacts.</p> <ul style="list-style-type: none"> • This may cause a fault. |
| | <p>Do not install this unit in a location where there is a possibility of adverse effects occurring due to atmospheric pressure, temperature, ventilation, sunlight, dust, salinity, sulfur/ozone in the air etc.</p> <ul style="list-style-type: none"> • This may cause a fault. |
| | <p>Do not install this unit in the vicinity of equipment that generates electromagnetic waves such as communication equipment, elevators etc.</p> <ul style="list-style-type: none"> • This may cause a malfunction. |
| | <p>Keep heaters away from the device. Also, make sure that it is not exposed to warm air directly.</p> <ul style="list-style-type: none"> • Heat softens and expands the tube, causing breakage or other damage. |
| | <p>Do not install this unit in a location which does not meet the working environment conditions stipulated below.</p> <p>① temperature: 10-35°C ② RH: 30-75% (without condensation) ③ Air pressure: 700-1060 hPa</p> <ul style="list-style-type: none"> • This may cause a fault. |





1.2 Preparation

|  WARNING | |
|--|--|
|  | <p>Use tap water to supply the water line of the main unit.</p> <ul style="list-style-type: none"> • The use of cleansers, industrial water, unhygienic water etc. may damage the patient's health. Moreover, this may damage the pipes inside the main unit and may cause a fault. |

1.3 Connection of Instruments

|  CAUTION | |
|---|---|
|  | Connect the main tube of each instrument before starting use. |
| | <ul style="list-style-type: none"> • An inadequate connection may cause a water or air leak. If a connector is pushed at an angle or if it is forcibly turned and bent, there is a danger of damage. |
| | Keep each instrument in its holder when not in use. <ul style="list-style-type: none"> • An accident/fault may occur due to unforeseen circumstances during operation of the vacuum equipment/instruments. |

Connect the main tube to the tray, assistant-side holder, and unit, and put the instruments in their holders. Refer to the following.

- For each main tube connection  Supplied installation control standard
- For the syringe case/nozzle of the three-way syringe connection  pp. 57-60
- For the vacuum syringe/saliva ejector  pp. 61-63
- For various instrument connections  see the operation instructions supplied with each product

1.4 Installation of Filters

|  CAUTION | |
|--|---|
|  | Before commencing use, always ensure that filters are fitted to each part. |
| | <ul style="list-style-type: none"> • Failure to install filters or improper installation may lead to a drop in performance, faults/pipe obstruction etc. |

Each part is equipped with a filter to protect the inner parts from contamination and foreign matter.

For how to install, refer to corresponding items in "5. Caring for the Unit" of these operation instructions.

1. Vacuum filter for vacuum pipeline
2. Vacuum filter for saliva ejector
3. Basin filter
4. Drain trap filter
5. Muffler sponge
6. Sterapore cartridge (for water)
7. Sterapore cartridge (for air) Option

2 Part Names

2.1 Chair Type

■ Contour type



Stand unit

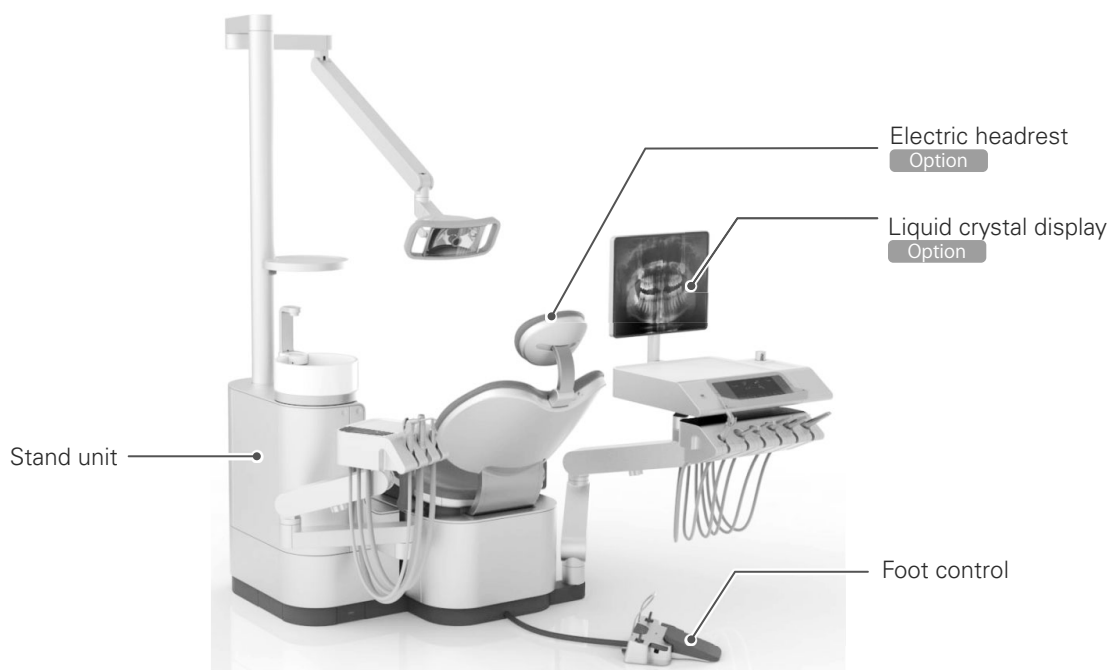

■ Foot support type

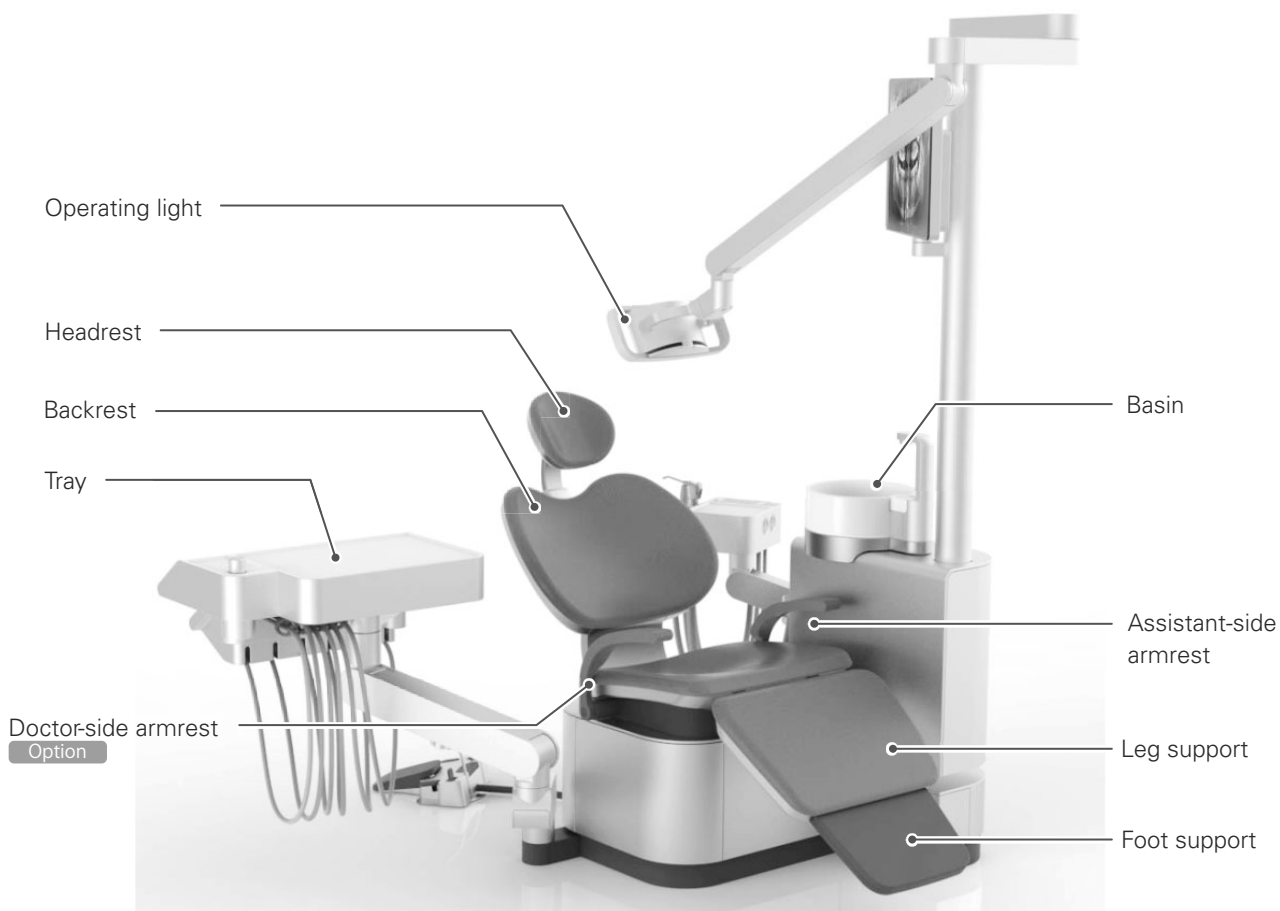

Chair mount unit

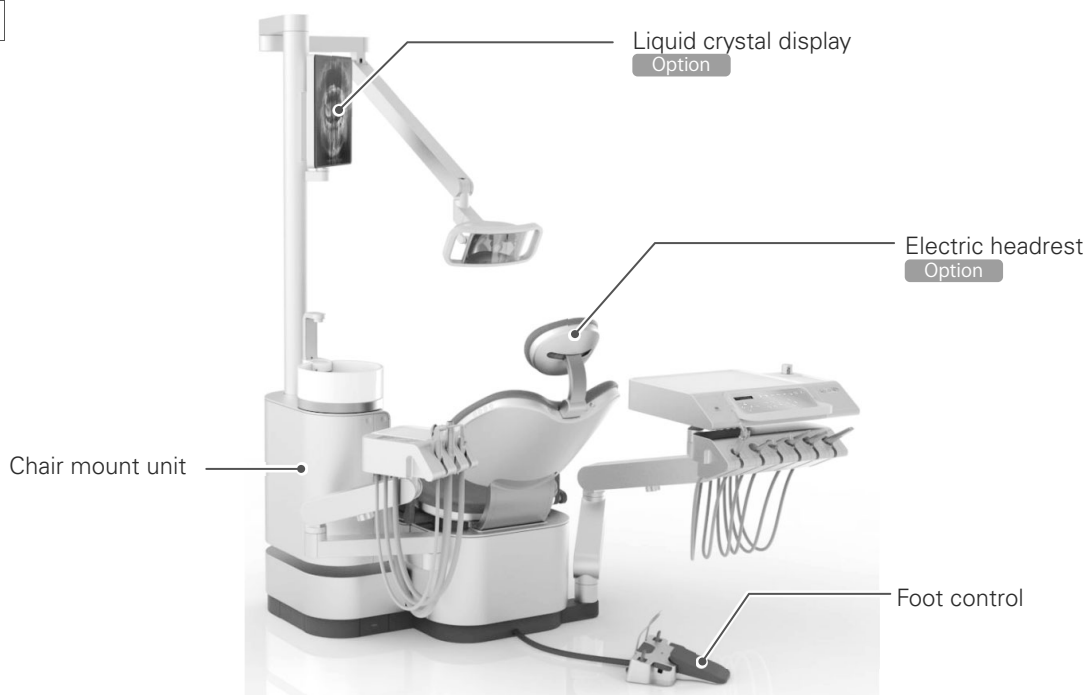

2.2 Tray Type

■ Floor-mounted tray type



■ Over-the-patient tray type



■ Cart



2.3 Operation Panel

■ Doctor-side operation panel

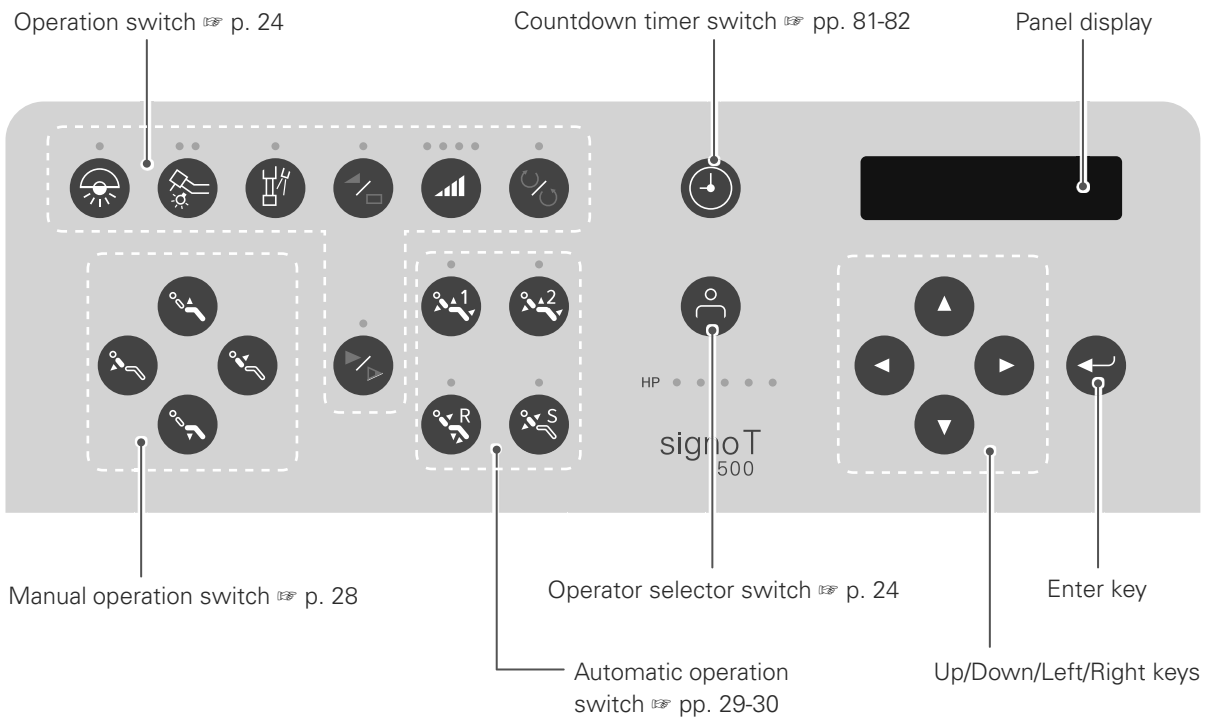

■ Assistant-side operation panel

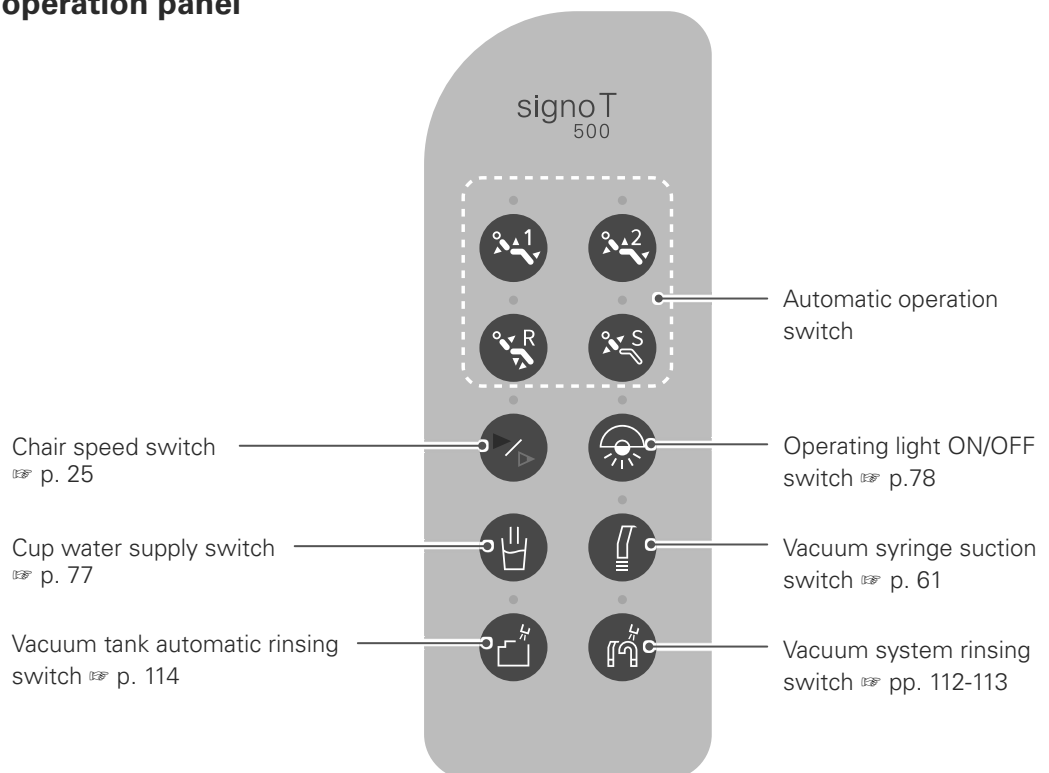

2.4 Foot Control

■ Name of Each Part

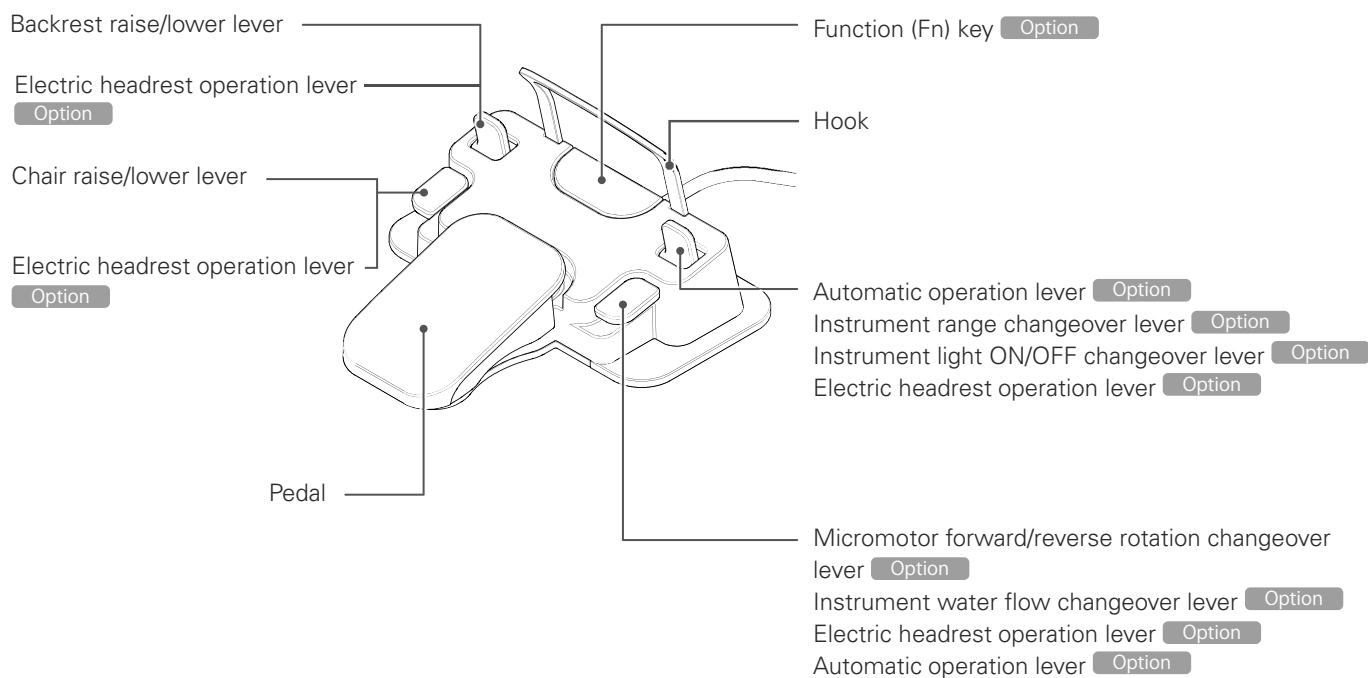

2.5 Accessories

| | | | |
|--|----------|---------------------------|----------|
| Tray paper | 1 set | MAZAK P | 1 bottle |
| Paper cup | 1 set | Protection sheet | 3 sheet |
| Top for paper cup | 1 set | Operation instructions | 1 copy |
| Headrest cover | 1 | Installation instructions | 1 copy |
| Spare fuse | 1 set | Warranty Card | 1 copy |
| Dedicated cleaner for cleaning | 1 bottle | Safety notes | 1 copy |
| Air nozzle (for removing spray solution) | 1 | | |

Other accessories for each instrument are included.

3 Actions Before and After Use

Refer to the various operation instructions for details of handling the air turbine handpiece, micromotor handpiece, operating light etc. (separate volumes).

Use this unit in the following environment.

Temperature: 10-35°C, humidity: 30-75%RH (without condensation), air pressure: 700-1,060hPa

※ When using equipment that has not been used for a while, always be sure to check that the equipment operates normally and safely prior to use.

3.1 Preparation Before Use

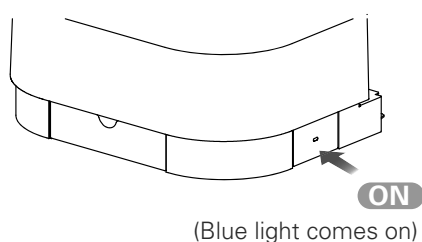
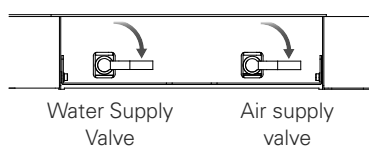
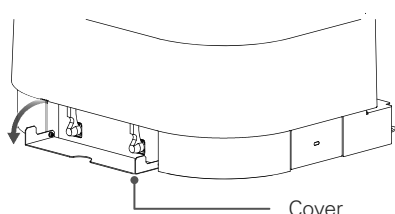

3.1.1 Water/Air Supply and Main Switch



1 Open the water supply/air supply valves

- ①. Open the cover.
- ②. Lower the water supply valve/air supply valve lever in the direction of the arrow and open the water supply/air circuits in the chair.

2 Turn the power ON

|  CAUTION | |
|---|---|
|  | When power is ON, do not subject the main unit to impacts or vibration. <ul style="list-style-type: none">• Accidents and faults due to unforeseen circumstances may occur. |
|  | When switching the power ON, check that the switches for operation of the device such as Up/Down, Upright/Reclining positions of the chair are not ON. <ul style="list-style-type: none">• The device may suddenly start to move and there is the risk of injury. |

Press the main switch of the chair. The power comes ON.

The power goes OFF automatically if the chair has not been operated for a certain period of time.

(= automatic power OFF function: initial setting is 120 minutes)

Automatic power OFF function

☞ p. 87

3.2 Interruption/Completion of Use

| ⚠ WARNING | |
|------------------|--|
| ! | <p>Always turn the main switch OFF and close the water supply valve when treatment has been completed, when the device is not used for a long time, or when there is a malfunction/abnormality.</p> <ul style="list-style-type: none"> • Accidents and faults/problems such as fire due to a short circuit and water leakage may occur. |
| | <p>Ensure that all wiring, tubes etc. are connected when supplying power and water/air to the main unit.</p> <ul style="list-style-type: none"> • Failure to do so may result in accidents and faults due to a short circuit, heat generation, water leaks etc. |
| ⊘ | <p>Do not expose the power supply to water or leave dust adhering to it.</p> <p>If there is a water leak, turn the main switch OFF, stop using the device, wipe away moisture and dry thoroughly before resuming use.</p> <p>If there is adhering dust, turn the main switch OFF and wipe dust off with a dry cloth etc.</p> <ul style="list-style-type: none"> • If use of the unit is continued while there is an abnormality, accidents and faults such as fire and electric shock due to a short circuit, heat generation etc. may occur. |

■ When use is interrupted, after completion of treatment

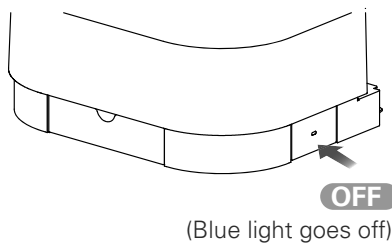

1 Turn the power OFF

Press the main switch of the chair.
The power goes OFF.

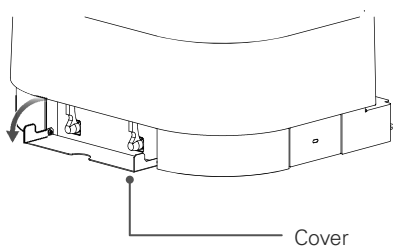

2 Closing the Water Supply/Air Supply Valves

①. Open the cover.

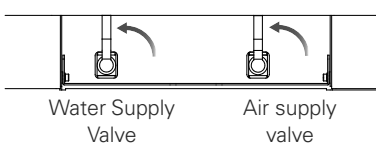

② Raise the water supply valve/air supply valve lever in the direction of the arrow and close the water supply/air circuits to the chair.

③ Close the cover.

■ In Event of a Fault or Abnormality

If a fault or an abnormality occurs, always be sure to turn the main switch OFF and shut off the water and air supplies.





- when the water supply does not stop such as with the failure of an automatic filler
- when replacing the sterapore cartridge
- when a localized water leak is detected
- when there is a failure/repair request
- when there is a disaster such as an earthquake

3.3 Storage

Observe the following storage/transportation conditions when storing/transporting the main unit.

- ① Temperature: -10-70°C
 - ② Humidity: 10-85% RH (without condensation)
 - ③ Air pressure: 700-1,060hPa
 - ④ Do not install the unit in an unstable location, such as on a slope or on a site subject to vibrations or impacts.
 - ⑤ Do not install this unit at a site where there is a possibility of adverse effects occurring due to atmospheric pressure, temperature, ventilation, sunlight, dust, salinity, sulfur/ozone in the air etc.
- Failure to comply may cause a fault.

4 Method of Operation

|  WARNING | |
|--|---|
|  | <p>Do not place objects or bring fingers, feet, or footwear near to movable parts such as the seat and backrest hinge of the main unit. (refer to the List of Precautions)</p> <ul style="list-style-type: none"> • There is a risk that items will be caught during operation and accidents such as injury and damage/faults may occur. |
| | <p>Do not place heavy objects on the edges of the seat/backrest/headrest or on the light/tray etc. and do not apply excessive forces to these areas.</p> <p>Avoid behavior such as standing/jumping on the main unit.</p> <ul style="list-style-type: none"> • There is a danger of the main unit toppling over or incurring damage and causing an accident or fault. |
| | <p>Do not spill liquid inside the main unit and do not insert easily combustible items and metals.</p> <ul style="list-style-type: none"> • If the unit continues to be used as is, there is a danger of accidents and faults such as fire/electric shock etc. |
| | <p>Do not place a heat source such as a heater near the main unit.</p> <ul style="list-style-type: none"> • There is a risk of deformation and damage to the main unit and rupture of the piping due to residual air pressure. |
|  | <p>Observe the following points during operation of the main unit and refer to the “List of Precautions” in the next section to ensure safety.</p> <ol style="list-style-type: none"> ① Apart from doctors and assistants, no-one should operate the main body without permission (as a mischievous prank etc.) ② Keep an eye on patients (especially infants and the elderly) ③ Do not allow patients to adopt a dangerous posture (put their legs on either side of the seat, stand on the seat, kneel on the seat, sit while wearing footwear such as heels and slippers etc.) ④ Do not let movement/posture exert a heavy burden on patients (such as a sudden headrest operation for patients with a cervical vertebrae disorder or adopt a supine posture while suffering back pain etc.) ⑤ Do not allow hands, parts of the body/belongings etc. to come close to the movable parts of the main unit and vicinity (do not allow the patient to grasp the tray arm, place hands at the base of the backrest, sit with a phone in their pocket, etc.) ⑥ Do not allow more than one patient on the seat (holding a child etc.) ⑦ Do not let anyone unrelated to treatment enter the surrounding area (such as a child approaching/touching the unit) ⑧ Do not move the small tray etc. close to the surrounding walls/windows/equipment/appliances etc. (collision may occur during operation etc.) ⑨ Do not behave in a way considered to be dangerous ⑩ Do not operate the chair in a situation that is considered to be dangerous <ul style="list-style-type: none"> • There is a danger of accidents causing injury etc., damage/faults occurring. |
| | <p>If there is a risk of injury or a collision during automatic operation of the main unit, carry out the following stop procedures immediately.</p> <p>(A) Step on the foot pedal</p> <p>(B) Operate the manual operation lever (either up, down, upright, or reclined)</p> <p>(C) Turn the main switch OFF</p> <ul style="list-style-type: none"> • There is a danger of accidents causing injury etc., damage/faults occurring. |
|  CAUTION | |
|  | <p>If a patient uses a pacemaker, do not simultaneously use the ultrasonic scaler, electrocautery scalpel and root canal length measuring instrument.</p> <ul style="list-style-type: none"> ● The pacemaker may malfunction and damage the patient’s health. |
| | <p>Always be sure to turn the main switch OFF when using an electrocautery scalpel near and around the main unit. Refrain from using devices generating electromagnetic waves such as cell phones etc.</p> <ul style="list-style-type: none"> • Malfunctions arise due to electromagnetic waves and an accident/fault may occur due to unforeseen circumstances. |

4.1 Precautions When Operating the Chair

Always carry out a safety check before operating the chair (automatic/manual). In particular, take care to avoid touching or pinching the patient and surrounding instruments etc. by following the precautions shown in the figure below.

4.1.1 Precautions When Operating the Chair

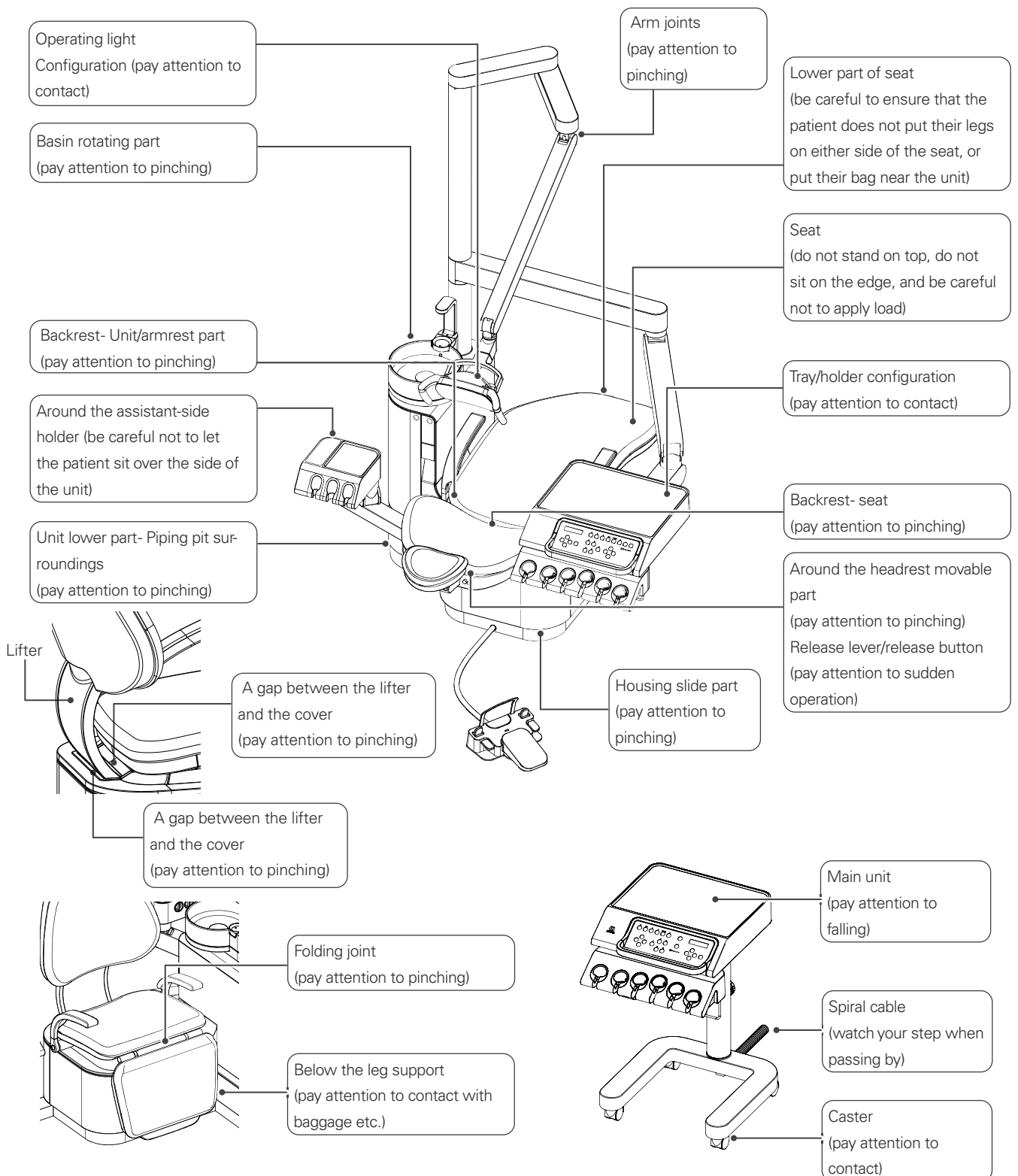

4.1.2 Safety Switch

■ Automatic Shutdown Using the Safety Switch

If any of the following situations arise during automatic operation, the safety switch is activated and the system stops automatically. The display shows that the system has automatically stopped or the safety lock is on. Check the relevant part, remove the obstruction then resume use.

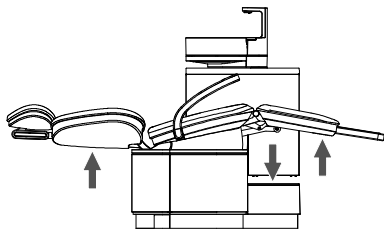

SAFETY SW
SEAT DOWN

- ① While descending, the backrest is pushed from below. Or, the piping pit is pushed from above. And also the undersurface of the leg support is pushed upwards.

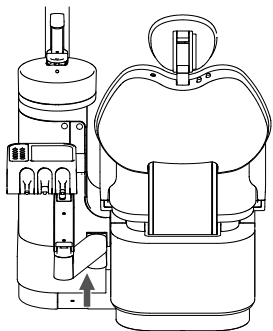

SAFETY SW
SEAT DOWN

- ② While descending, the assistant-side arm rises up.

SAFETY SW
SEAT UP

- ③ When the chair is going up, the assistant-side arm rises up. (Stand unit)

SAFETY SW
BACKREST UP

- ④ While uprighting, the assistant-side arm rises up.

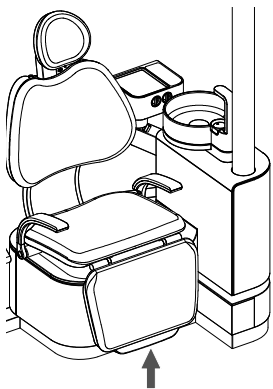

SAFETY SW
SEAT DOWN

- ⑤ While descending, the edge of the foot support is pushed.

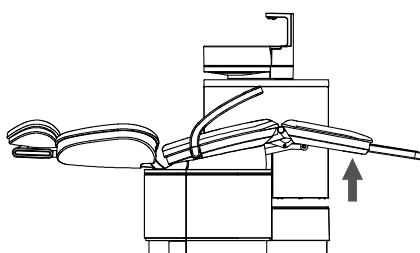

SAFETY SW
BACKREST UP

- ⑥ While uprighting, the back side of the foot support is pushed upward.

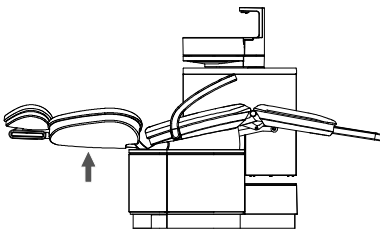

SAFETY SW
BACKREST DOWN

⑦ While reclining, the backrest rises up.

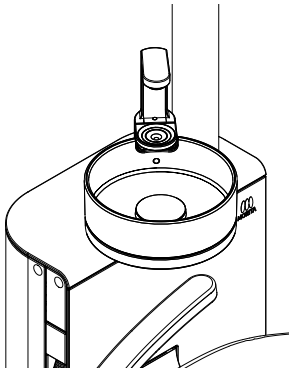

SAFETY LOCK SW
BASIN

⑧ While the chair and the backrest is going up, the basin moves towards the patient. Or, an operation to raise the chair or raise the backrest is performed when the basin is at the patient's side. When the chair is going down, the basin moves towards the patient.

Or, an operation is performed to lower the chair when the basin is at the patient's side. (stand unit type only)

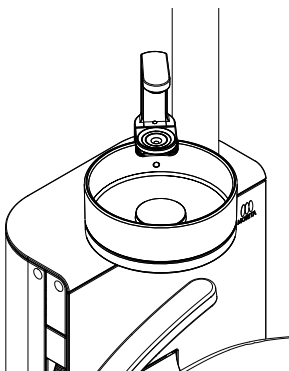

SAFETY LOCK SW
BASIN

⑨ While ascending, the basin moves to the patient's side.

Alternatively, if the ascending is performed when the basin is at the patient's side. (stand unit type only)

4.2 Operation Panel

4.2.1 Operation Switch

| | |
|------------------|---|
| ⚠ WARNING | |
| ! | Always be sure that rotation/vibration has stopped when changing over and adjusting instruments. • Accidents and faults due to unforeseen circumstances may occur. |

Carry out each operation using the switches on the operation panel.

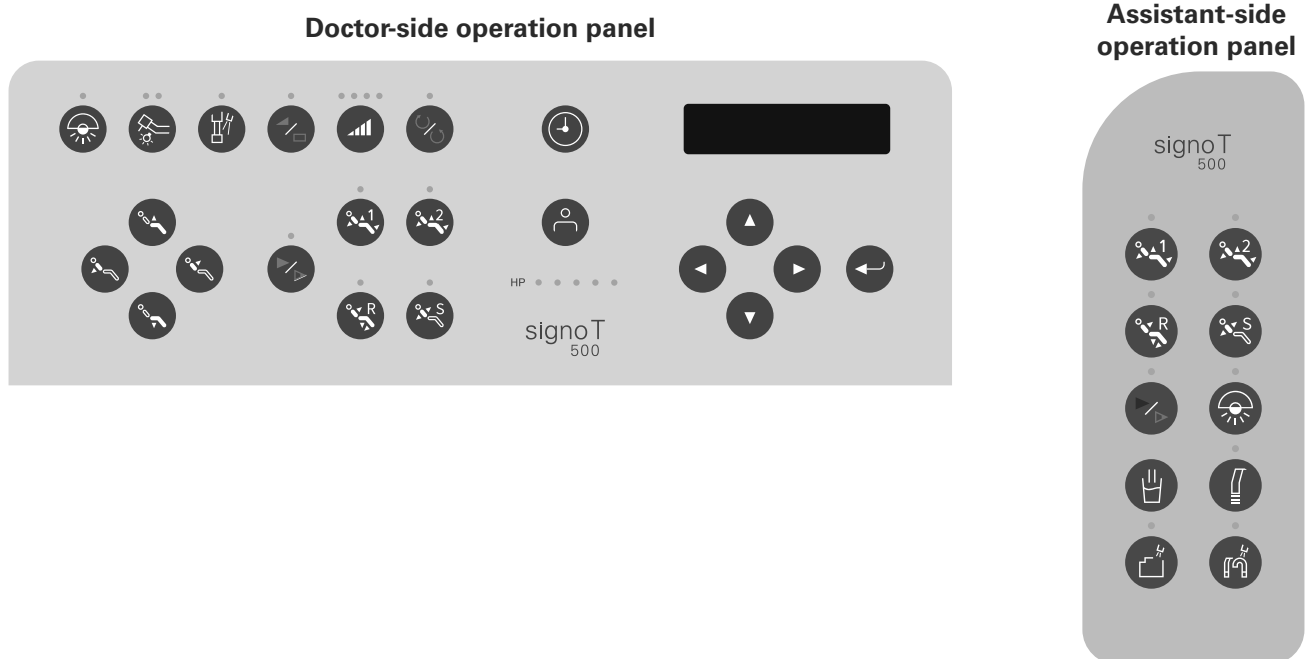

■ Operator selection



Switches operators.

It is possible to register up to 5 settings patterns such as instrument settings and individual user settings.

These can also be registered using the Enter key or the Up/Down/Left/Right keys.

[p. 83](#)

■ Instrument selection



When you pick up an instrument from the doctor-side holder, the instrument enters the selected state and can be used.

Its selection takes priority until it is returned to the holder.

■ Instrument settings

Each time a switch is pressed, the selection changes and this is indicated by a light.



Instrument light ON/OFF (when picked up and put back)

Switches instrument light ON/OFF.
Brightness can be adjusted to 2 levels.

- Orange & goes off: OFF
- Blue & goes off: ON
- Orange & blue: ON (high brightness)

NOTE: Does not function without a light being specified (light remains off)



Instrument water flow ON/OFF (when picked up and when put back)

Switches instrument water flow ON/OFF.

- Orange: OFF
- Blue: ON



Changes instrument speed between variable speed and constant speed (when picked up)

Changes the rotation speed of the instrument.
Each press, switches between variable speed and constant speed.

- Orange: constant speed
- Blue: variable speed

Constant speed: the speed of rotation (maximum speed) is constant regardless of the pressure on the foot pedal.

Variable speed: the speed of rotation changes according to the pressure on the foot pedal.



Change in the direction of rotation of the micromotor (when picked up)

Changes the direction of rotation of the micromotor.
Changes from forward rotation to reverse rotation each time it is pushed.



Chair speed switching

Changes chair operation speed.
Each press switches between slow speed and standard speed.
Changes between manual and automatic operation.

- Orange: low speed
- Blue: standard speed



Changes the instrument range (when picked up)

Changes range of relevant instrument.

- Micromotor
- Ultrasonic scaler Option

■ Chair Speed switching

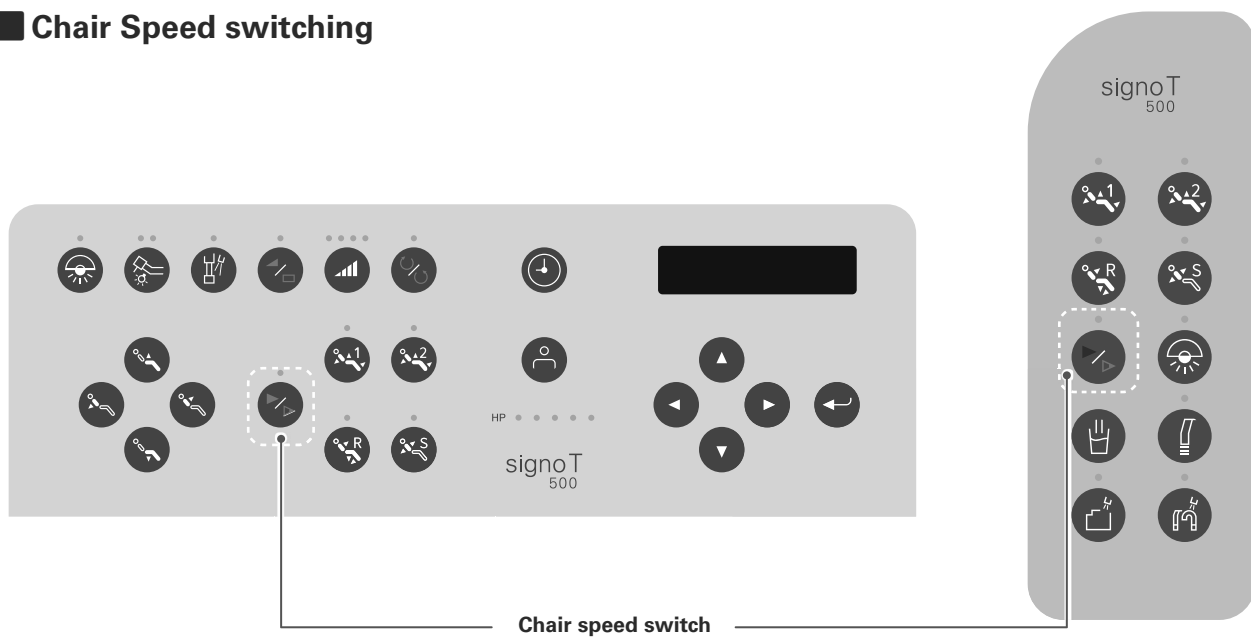

Press the chair speed switch on the operation panel to raise or lower the chair or move the backrest upright at a slower speed than normal. Press again to return to normal speed.

■ Operating light ON/OFF



Switches the operating light ON/OFF.

■ Other operation switches



Cup water supply

Manual supply of cup water.

Water is supplied while the switch is pressed.



Vacuum syringe suction

Switches vacuum syringe suction ON/OFF.

This can be operated while the syringe is out of the holder.



Vacuum tank automatic rinsing

Automatically rinses the vacuum tank.

Pressing the switch to automatically rinse the inside of the vacuum tank.



Vacuum system rinsing

Rinse out the vacuum piping and saliva ejector piping.

Position the vacuum syringe and the saliva ejector in the unit and press the switch to start rinsing.

4.3 Chair

4.3.1 Manual Chair Operation

■ Raising and lowering the chair

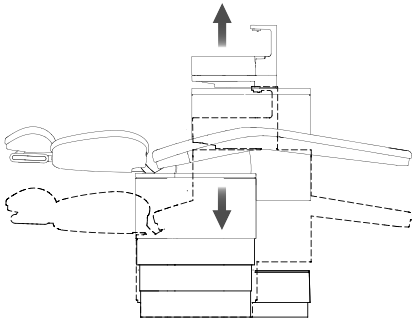

Raise and lower the chair using the manual operation switches on the operation panel or the foot control. Chair operation is possible during this process.



Operation Panel

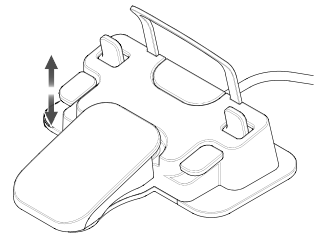

■ Moving the backrest upright

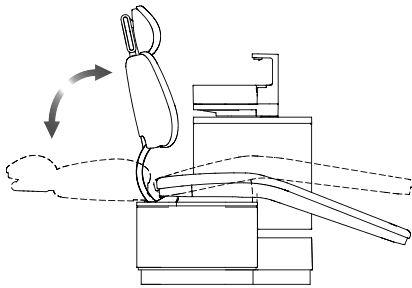

Make the backrest upright using the operation panel or foot control. Chair operation is possible during this process. During this operation, the backrest temporarily stops at the backrest reset position. To make it more upright, release the lever and then operate it again.

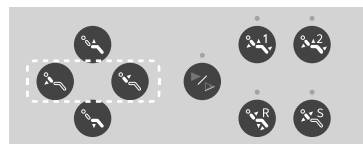

Operation Panel

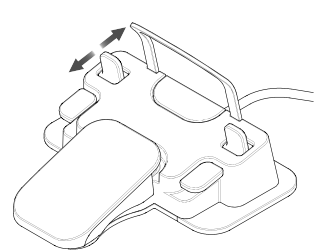

Foot support specifications

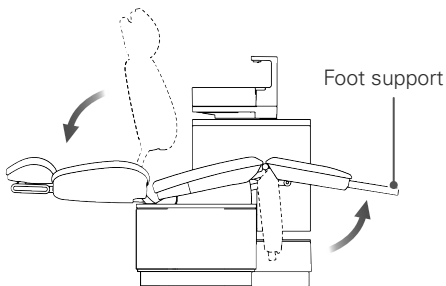



When the backrest is flattened, the foot support comes out to provide the patient's feet.

None of the above chair operations will work while the air turbine handpiece or micromotor is running or while the ultrasonic scaler is in operation.

4.3.2 Automatic Movement of Chair

⚠ WARNING

| | |
|---|---|
|  | Do not leave the chair when in operation and make sure that the patient is in the correct posture. • There is the risk of accident such as injury. |
|  | Do not push any switch with a sharp object such as a dental instrument as this could damage the switch surface. • This may cause a malfunction or fault. |

Used to move the seat up and down and make the backrest upright automatically.

Press any of these switches once to automatically move the seat and backrest to a corresponding stop position.

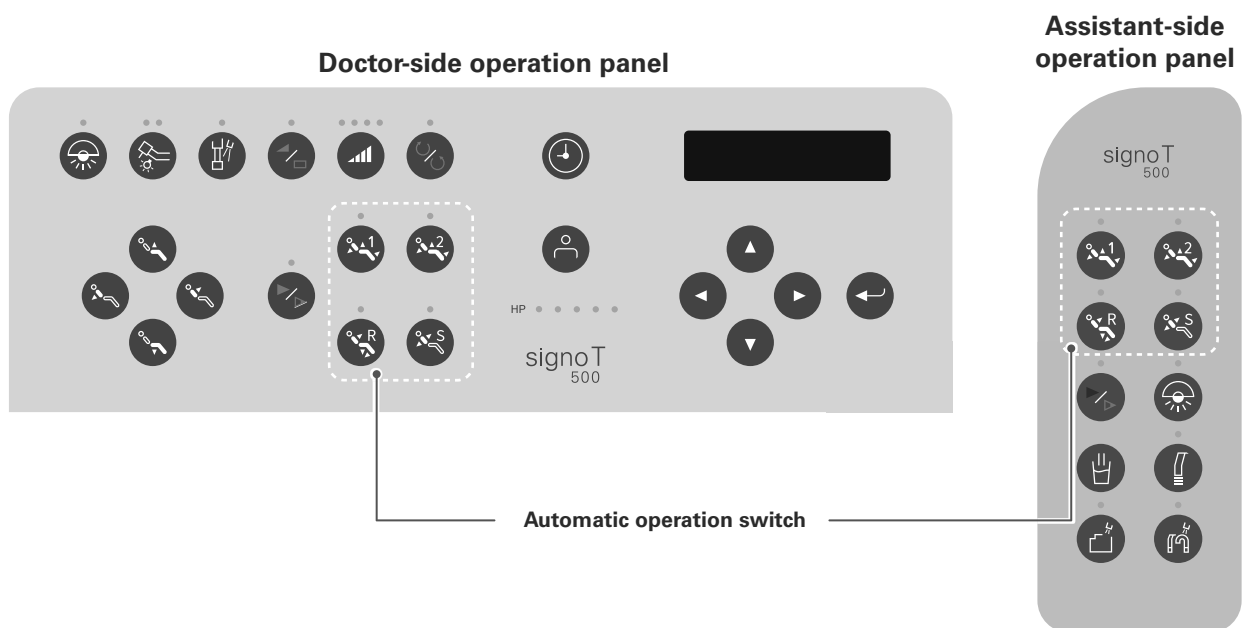

■ AUTO 1/AUTO 2



Switch operation

Mainly used at the start of treatment.
Operates each set treatment position.

(Setting the treatment position)

- ① Move to the desired position using the manual operation switches on the operation panel, or the chair raise/lower lever and backrest raise/lower lever on the foot control.
- ② Press and hold the desired switch (AUTO 1 or AUTO 2) for about 5 seconds. Setting is completed if the "beep" alarm sounds.

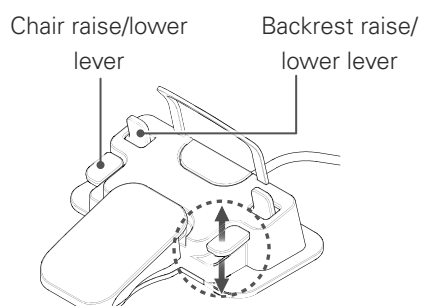

Foot control operations (extended function) Option

Operate the lever on the foot control.

(hold the lever for 1 second or more to prevent malfunction)

Up position: AUTO1

Down position: AUTO2

Reset



Switch operation

Mainly used at the completion of treatment.
The seat and backrest move to the set positions.
(factory settings- seat: 450mm, backrest: 70°)

(Setting the treatment position)

- ① Move to the desired position using the manual operation switches on the operation panel, or the chair raise/lower lever and backrest raise/lower lever on the foot control.
- ② Press and hold the reset switch for about 5 seconds. Setting is completed when the "beep" alarm sounds.

NOTE: Cannot be set on the assistant-side operation panel.

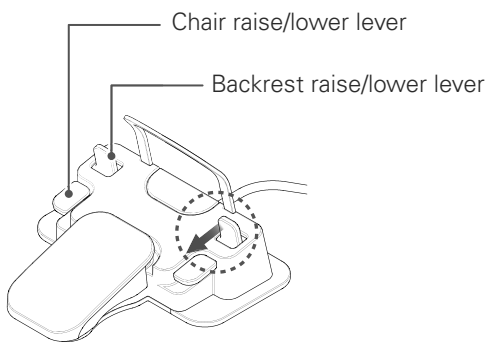

Foot control operations (extended function) Option

Operate the foot control lever in the direction of the arrow.
(hold the lever for 1 second or more to prevent malfunction)

Soft Memory



Switch operation

Mainly used to allow gargling and to return to the original treatment position.
Moves to the gargle position when pressed once. The chair moves to the lowest position and the backrest moves to the most upright position (about 70°) (factory setting). Press once more to return to the previous treatment position.

The gargle position can only be set when the chair is in the vertical position.
(Setting the chair vertical position)

- ① Move to the desired position using the manual operation switches on the operation panel, or the chair raise/lower lever and backrest raise/lower lever on the foot control.
- ② Press and hold the soft memory switch for about 5 seconds. Setting is completed if the "beep" alarm sounds.

NOTE: Cannot be set on the assistant-side operation panel.

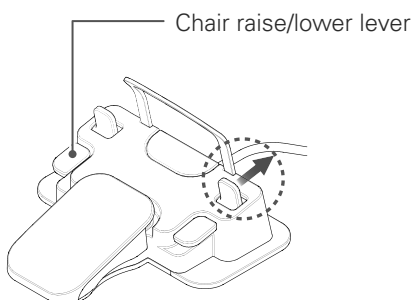

Foot Control Operation Option

Operate the foot control lever in the direction of the arrow.
(hold the lever for 1 second or more to prevent malfunction)

■ Interrupting Automatic Operation

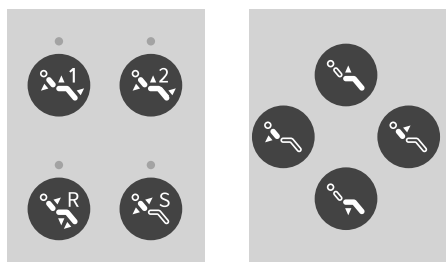

Manual Interruption of Automatic Operation

To stop automatic operation, perform one of the following operations.

- Press any automatic operation switch
- Press any switch for manual operation
- Step on the foot control pedal
- Operate a manual operation lever on the foot control
- Turn the main switch OFF.

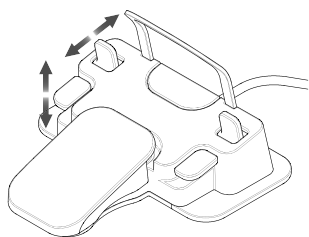
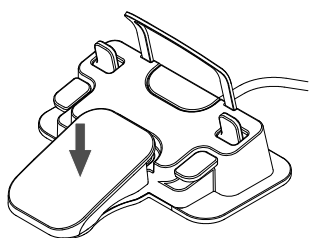

■ Chair Lock Switch

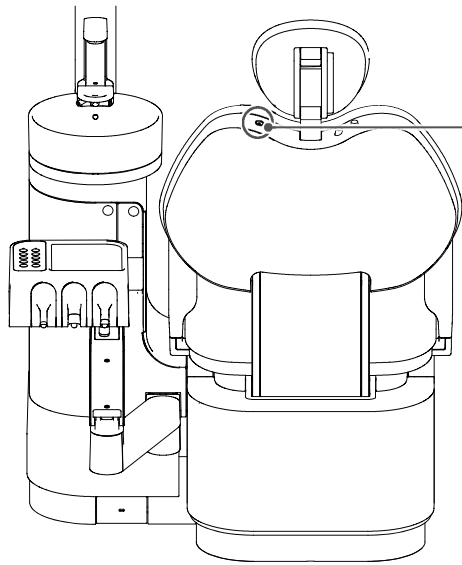

Press the chair lock switch if you want to disable the functions of the chair.
(the light on the switch is lit while the chair is locked)
Instruments can be used.

Press the switch again to cancel operation.

NOTE: The chair will not operate even if the switches of the foot control,
the chair position automatic switches, or the raise/lower switches are
used.

4.3.3 Cordless Foot Control Option

⚠ WARNING



Behavior may become unstable due to communication trouble. If abnormality occurs, please discontinue use.

- There is the risk of an accident due to a malfunction.



Always be sure to turn OFF the main switch of the chair unit and the power switch of the cordless foot control when replacing the batteries.

- The chair may move suddenly and cause an accident.

■ Method of Operation

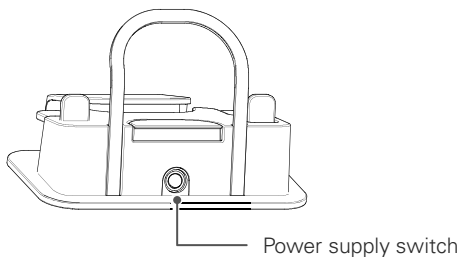

- ① Turn the power switch ON.
Operate the pedal and operate the chair.
- ② After the day's treatment, turn the power switch OFF.

■ Battery Replacement

The cordless foot control is powered by batteries.

Replace the batteries roughly every year.

Always be sure to turn OFF the main switch of the chair unit before replacing the batteries.

When replacing the batteries, please observe the disposal regulations in the applicable area.

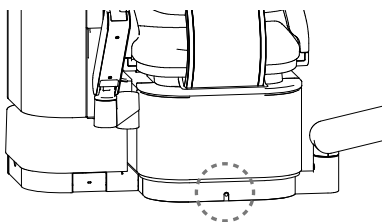

If the batteries are exhausted, the light at the base of the chair blinks.
(the light is usually off)
"LOW BATTERY" is displayed on the tray operation panel.

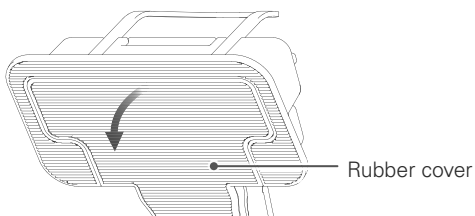

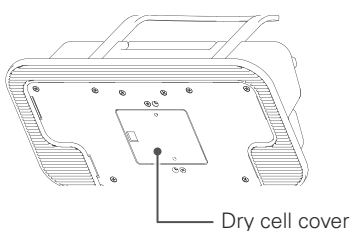

- ① Turn back the rubber cover on the lower surface.



- ② Remove the cover of the battery compartment and replace the batteries with new ones.
 - Use 3 alkaline AA batteries
 Do not use zinc-carbon batteries or rechargeable batteries.
The "LOW BATTERY" indication may appear early.
- ③ After replacing the batteries, replace the battery cover and rubber cover as before.

4.3.4 Headrest Height and Angle Adjustment

| ⚠ WARNING | |
|---|---|
|  | Do not put your fingers, hair, clothing etc. close to moving parts such as the headrest movable parts/slide bar. <ul style="list-style-type: none"> • Accidents due to pinching and jamming etc. may occur. |
| | Do not adjust the angle of the headrest while a patient is seated. <ul style="list-style-type: none"> • There is a risk of injury to the patient's neck/head due to sudden operation and the risk of damage/faults to the shaft part due to loads. |
|  | Any angle adjustment of the headrest should be carried out by the doctor. Do not allow an assistant or a patient to touch the release button or the release lever when the headrest is in an unsupported position. <ul style="list-style-type: none"> • This could result in a sudden drop or movement of the headrest, resulting in injury or causing an accident, damage or fault. |
| | When adjusting the angle of the headrest or shortening the slide bar, always move the headrest slowly while supporting it with your other hand. Check that it is securely fixed after adjustment. <ul style="list-style-type: none"> • The headrest may drop suddenly and accidents such as injury and damage/faults may occur. There is the risk that sudden movement may hurt the patient's neck/head. |

■ Twin-axis headrest

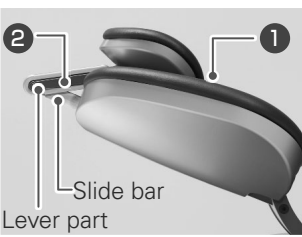
| ⚠ WARNING | |
|---|--|
|  | When adjusting the angle of the headrest and when setting it to the following position, push the headrest against the backrest (1) or tilt the lever part to the slide bar side (2). <ul style="list-style-type: none"> • For adjustment position shown in the following figure, when a load is applied while the head part (or lever) is not fixed it may damage the headrest, lever part and slide bar and cause accidents such as an injury. |
| |  |

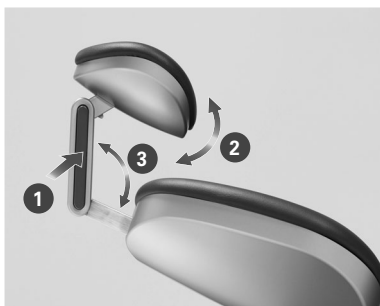

Angle adjustment

When the release lever (1) is pressed, the head portion (2) and neck portion (3) each move.

The angles are fixed at the position where the release lever is released.

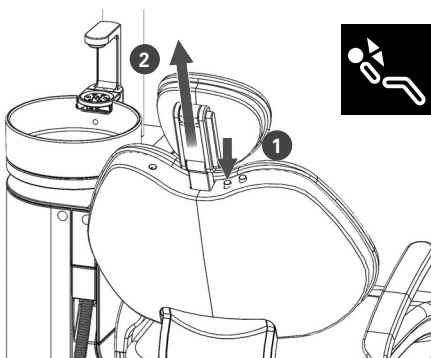

Height Adjustment

Have the patient take their head off the headrest.

While pressing the slide bar release button (1), hold the headrest and adjust the height (2). When the slide bar release button is released, the slide bar is fixed.

Electric Headrest Option

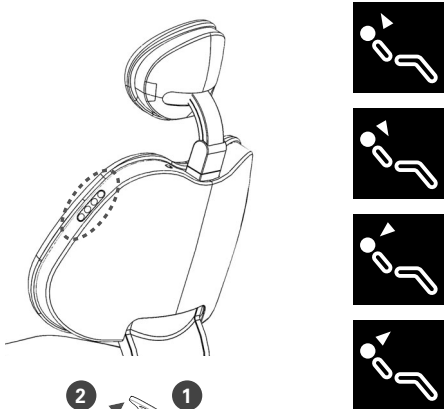

Angle/height adjustment

Adjust the height and angle of the headrest using the operation switches on the side of the backrest. Press and hold down the switches to make adjustments. Option

When the foot control function (Fn) switch (1) is pressed, height (3) and angle adjustment (2) are carried out with the foot control operation levers.

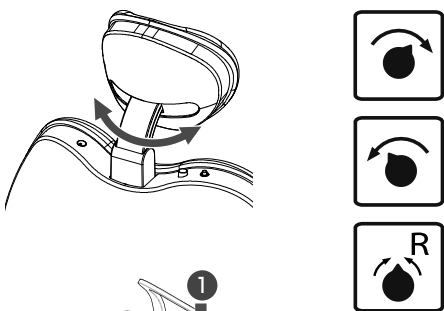

Rolling Operation Option

When the foot control function (Fn) switch (1) is pressed, rolling operation (2) and resetting operation (3) is carried out with the foot control operation lever only while it is ringing.

When the reset operation is performed, the headrest returns to the center position.

The alarm sounds for about 3 seconds. Please start operation during that time. If no operation is performed, it returns to the original state.

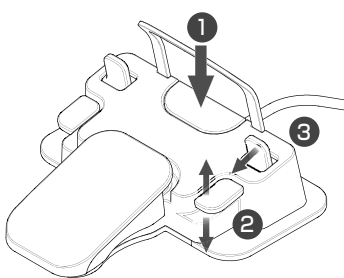

Rolling Operation (Operating stick for rolling) Option

Rolling operation of the backrest part When you knock down the operation stick, you can make the headrest stand up, tilt, turn left and right.

- Standing: 1
- Tilting: 2
- Left rotation: 3
- Right rotation: 4
- Rolling reset: 5

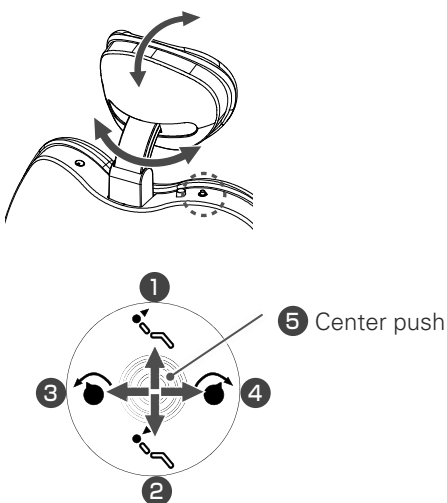

Natural Movement Headrest Option

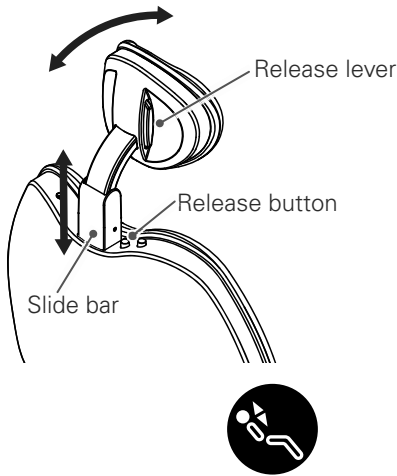

Angle adjustment

When the release lever is pressed, the headrest move. The angles are fixed at the position where the release lever is released.

Height Adjustment

Have the patient take their head off the headrest. While pressing the slide bar release button, hold the headrest and adjust the height. When the slide bar release button is released, the slide bar is fixed.

4.3.5 Backrest Height Adjustment

Backrest Slide Mechanism Option

| | |
|------------------|---|
| ⚠ WARNING | |
| | Do not put your fingers, hair, clothing etc. close to moving parts. <ul style="list-style-type: none"> • Accidents due to pinching and jamming etc. may occur. |
| ⚠ CAUTION | |
| | Always ensure that backrest height adjustment is carried out by the doctor. Do not allow an assistant or a patient to touch the release button when the headrest is in an unsupported posture. <ul style="list-style-type: none"> • Failure to do so will cause the backrest to move abruptly and accidents such as injury and faults may occur. Adjust the height of the backrest to the reset state (with the backrest upright) and do not apply a load to the seat surface. Check that it is securely fixed after adjustment. <ul style="list-style-type: none"> • If the patient is left reclining, the leather part may come off and damage/faults may occur. If treatment is started without checking the seat fixing, an accident may occur. |

Height Adjustment

While pressing the release button, the backrest can be slid and the height adjusted.

When extending the backrest, lift **(1)** the backrest to the desired height by holding the release button **(2)** and holding the backrest. When the release button is released, the position is fixed.

To shorten the backrest, push the backrest down from above while pressing the release button. When the release button is released, the position is fixed.

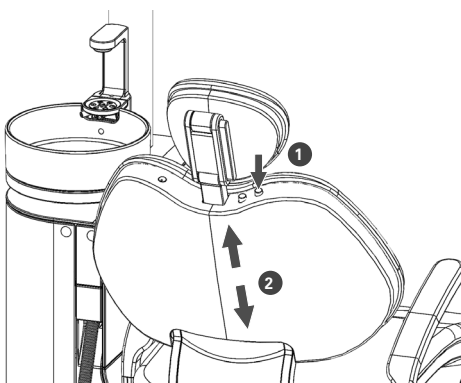

4.3.6 Armrest

■ Assistant-side armrest

This is a fixed armrest for the patient.

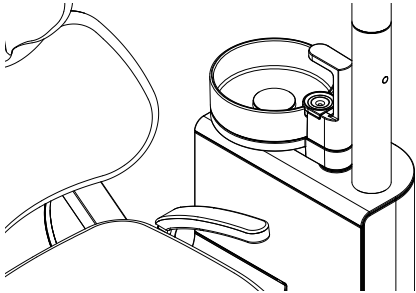

■ Doctor-side armrest Option

This is a movable armrest for the patient.

⚠ WARNING



Do not bring your fingers close to the pivot of the doctor-side armrest. Do not bring the doctor-side holder or any other item which the armrest might hit into the vicinity of the armrest.

- Accidents such as injuries due to pinching may occur.

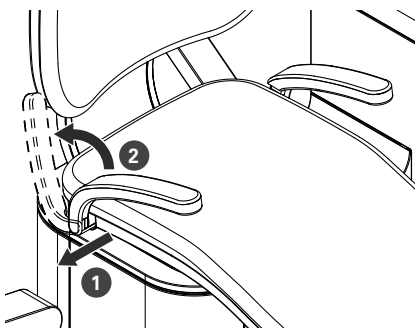

It can be raised up so as not to hinder the entry and exit of the patient. When it is lowered, it is locked and cannot be moved.

To raise or lower, pull the base of the armrest outward (1), then lift up (2).

To lower, lower the armrest to the position where it stops.

It will lock again at the lowest position.

4.4 Tray

| ⚠ WARNING | |
|------------------|---|
| ! | Do not apply a load of 30 N (3 kgf) or more to the doctor-side tray. |
| | Do not subject the tray to excessive loads or impacts. |
| | • If the load exceeds 30 N, the tray may drop and an accident or damage/fault may occur. |
| | Always adjust the doctor-side tray knob to the appropriate state. |
| | In particular, in the case of the cart-type tray, always be sure to fully tighten the fixing knob |
| | • The tray may drop and cause an accident or damage/fault. |

4.4.1 Tray

■ Tray

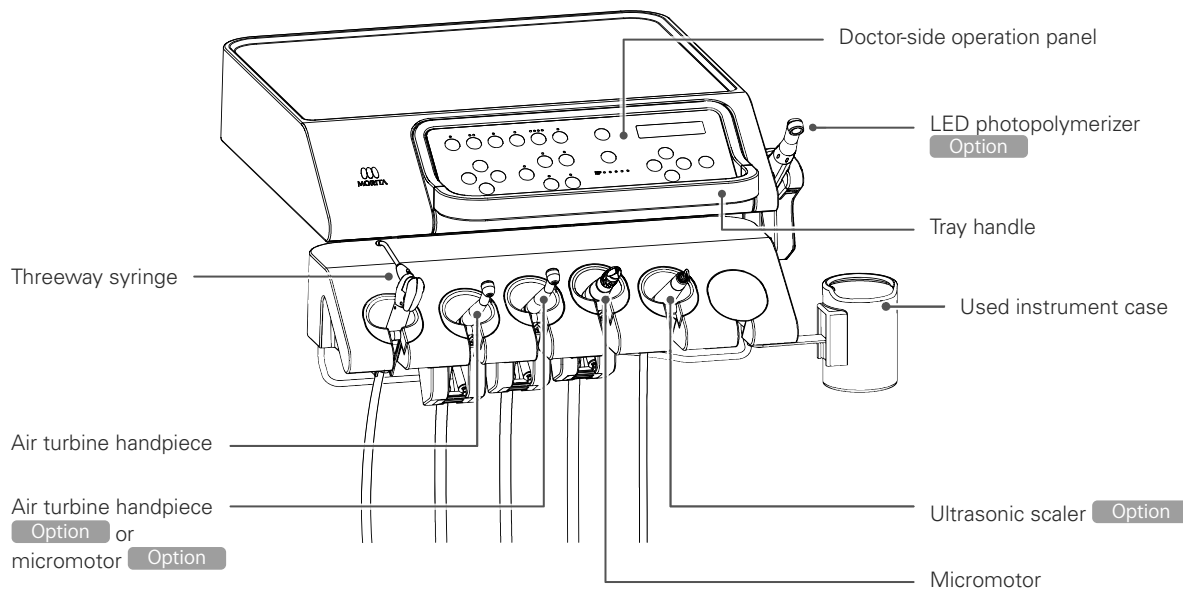

■ Used instrument case

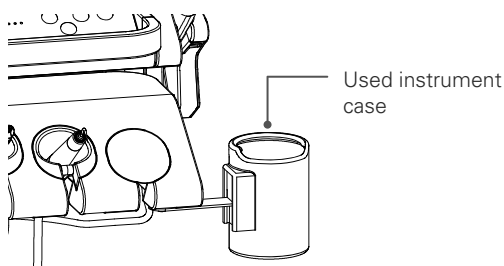

Use the included special paper cup inset in the used instrument case. Replace paper cups for new ones as needed. Dedicated paper cups are also available separately. When accessories run out, please place an order with a reseller or the nearest MORITA CORP. subsidiary.

■ Tray paper

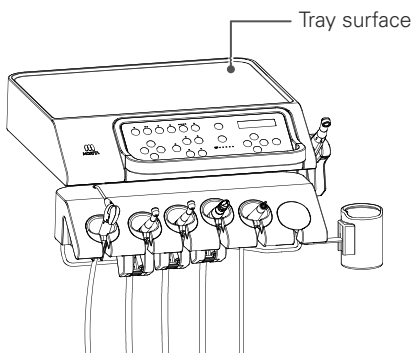

Use by laying on the tray.
 Replace the tray paper as needed.
 Dedicated tray papers are available separately. When accessories run out, please place an order with a reseller or the nearest MORITA CORP. subsidiary.

■ Silicone tray sheet Option

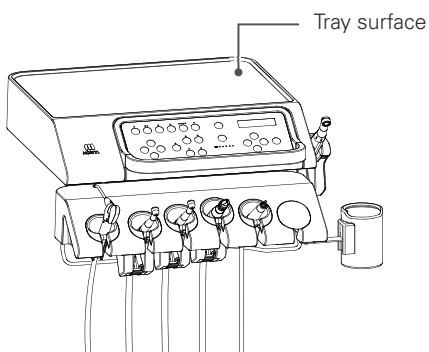

Use by laying on the tray.
 Autoclave and ethanol cleaning may be used.

■ Protective sheet for the operation panel

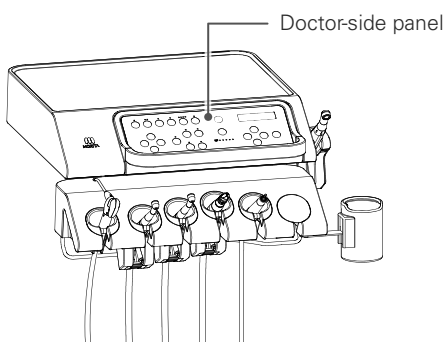

This is a protective sheet for the doctor-side operation panel and the assistant-side operation panel. It adheres to the panel surface and protects against scratches and dirt.
 Replace the protective sheet as needed.
 Protective sheets are also available separately. When accessories run out, please place an order with a reseller or the nearest MORITA CORP. subsidiary.

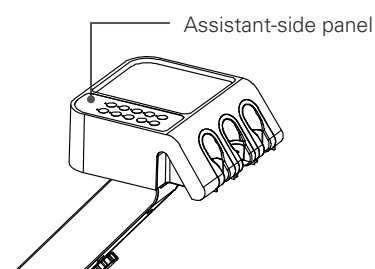

4.4.2 Over-the-Patient Tray Type/Floor-mounted Tray Type

■ Angle/height adjustment

The tray can be swiveled horizontally and pivoted vertically as shown in the figures below. Hold the tray handle and move it slowly.

Over-the-patient tray type

Horizontal movable range

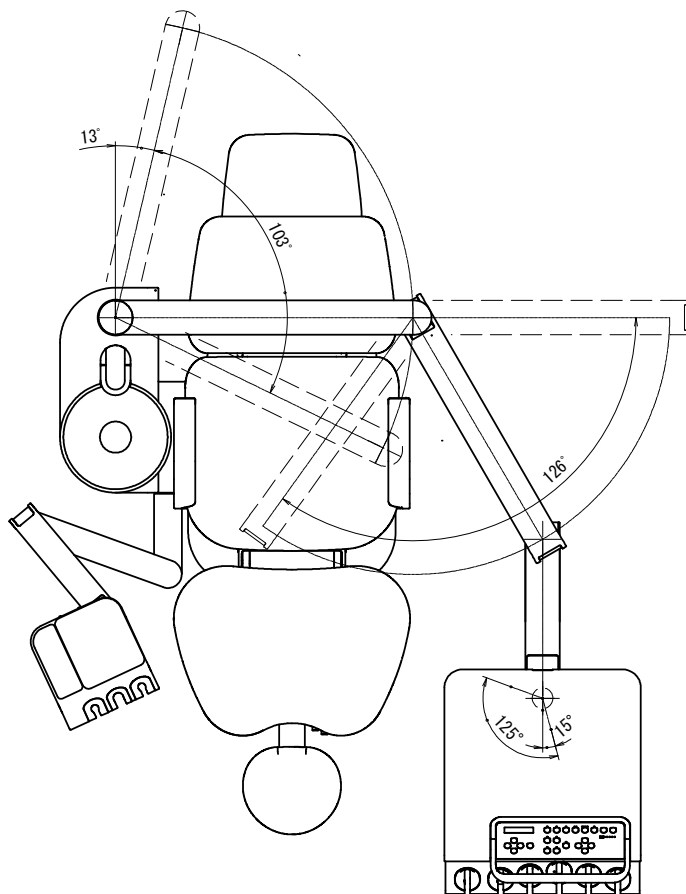

Vertical movable range

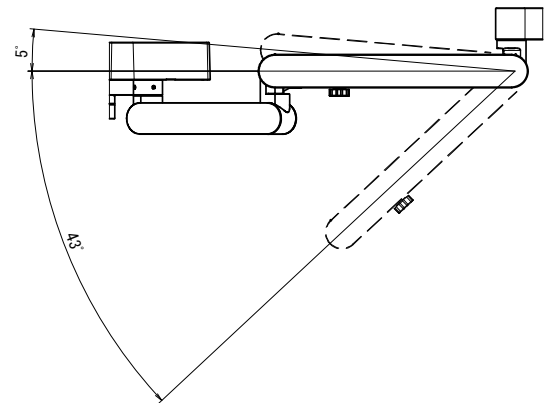

Floor-mounted tray type

Horizontal movable range

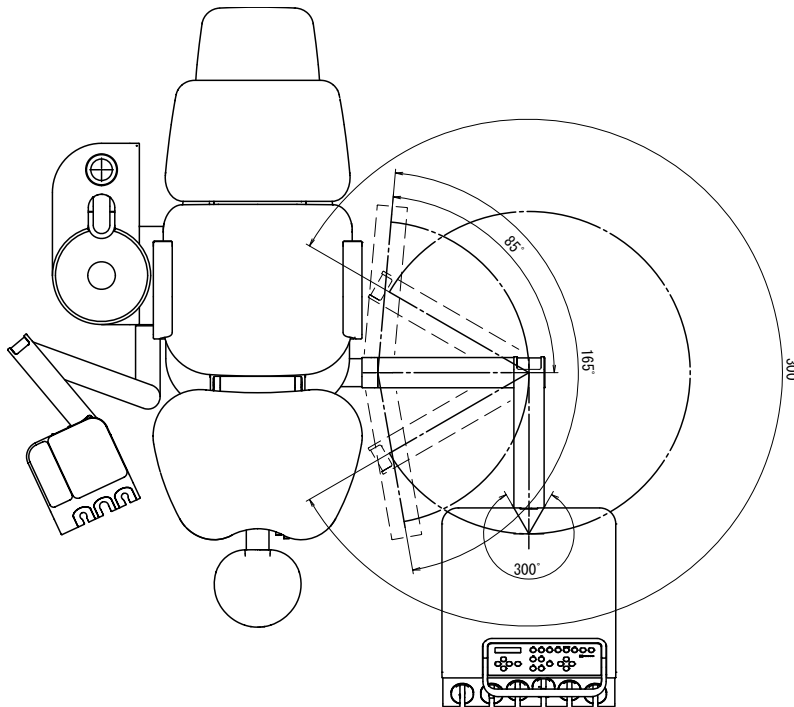

Vertical movable range

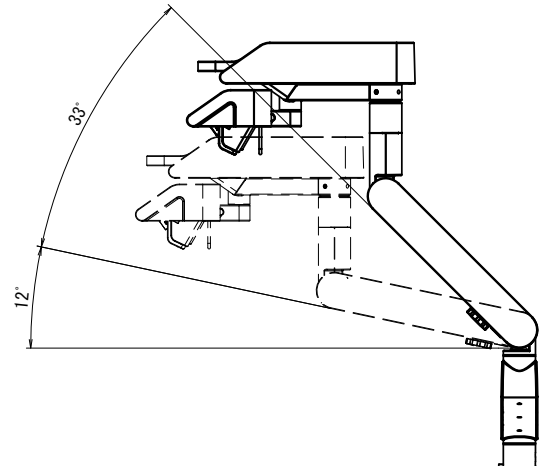

■ Adjustment of the force required to move the tray movable arm

You can adjust the force required to move the tray movable arm (below: movable arm) up and down to suit the weight of the objects being placed on the tray.

Follow the procedure below.

- ① When placing heavy objects on the tray, turn the knob of the movable arm part in the direction to tighten it. The force required to move the tray increases.
- ② When placing light objects on the tray, turn the knob of the movable arm part in the direction to loosen it. The force required to move the tray decreases.
- ③ To fix the vertical position of the tray, tighten the knob fully. This will fix the position of the movable arm, ensuring the tray does not move up or down. To release the tray, loosen the knob.

If the movable arm has been fixed in a low position, the tray may jump upward when the knob is loosened.

Always hold the tray handle when carrying out such adjustments.

Take care not to loosen the knob too much. It can come off and allow structural parts to drop off.

Over-the-patient tray type

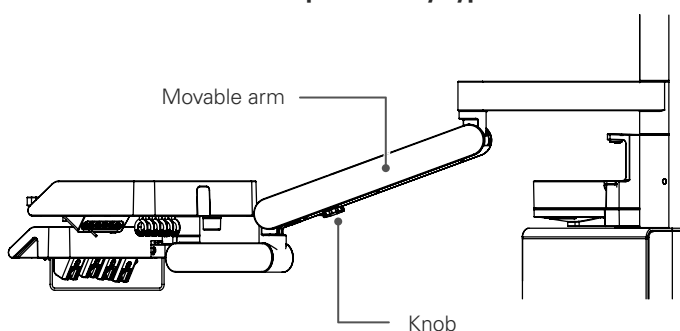

Floor-mounted tray type

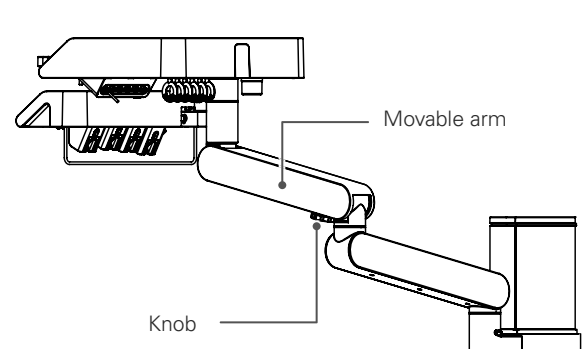

4.4.3 Cart

⚠ WARNING

Observe the following when operating the cart to ensure it is safe at all times.

- ① Alert passersby/patients that the hose from the chair is on the floor to prevent tripping.
- ② Do not move the cart with excessive force, rest your hands on it, stand items up on the tray, apply an unbalanced load, or engage in any other dangerous behavior.
- ③ Do not pull the hose, drag the cart by pulling the hose, forcibly bend the hose, or damage the hose by stepping on it etc.



- This may cause damage/faults.

Always be sure to use the cart on a level floor. Do not use the cart if it is tilted or has been knocked over.

- If the cart is tilted by 10° or more or if it is used where there is a difference in level, it may topple over and cause an accident or damage.

Always fully tighten the fixing knob.

- If insufficiently tightened, the tray may unexpectedly drop and cause an accident or damage.

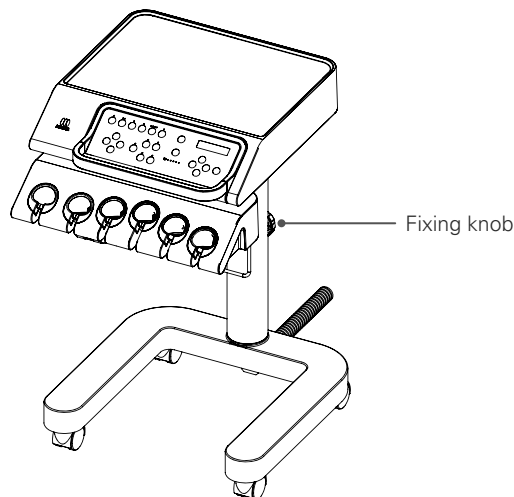

■ Operation

The cart can be freely positioned using the leg casters. Hold the tray handle and move it slowly.

■ Height Adjustment of Tray Surface

The height of the tray surface can be adjusted between a lowest position of 750 mm and a highest position of 950 mm. Follow the procedures below.

- ① With the doctor-side tray firmly supported, loosen the fixing knob on the support column.
- ② Set the tray to the desired height and re-tighten the fixing knob.

4.4.4 Auxiliary Tray Option

⚠ CAUTION

| | |
|----------|---|
| ! | <p>When raising the chair, move the auxiliary table to a safe position so that the patient and the chair do not contact the auxiliary table.</p> <ul style="list-style-type: none"> • This may cause injury and faults. |
| ⊘ | <p>Do not load more than 10 N (1 kgf) on the auxiliary table.</p> <p>Also, the load on the auxiliary table and the table should not exceed 30N (3 kgf) in total.</p> <ul style="list-style-type: none"> • This may cause faults <p>Do not lean on the auxiliary tray.</p> <ul style="list-style-type: none"> • This may cause injury and faults |

■ Operation

The auxiliary tray rotates 180°
Move to any position and use.

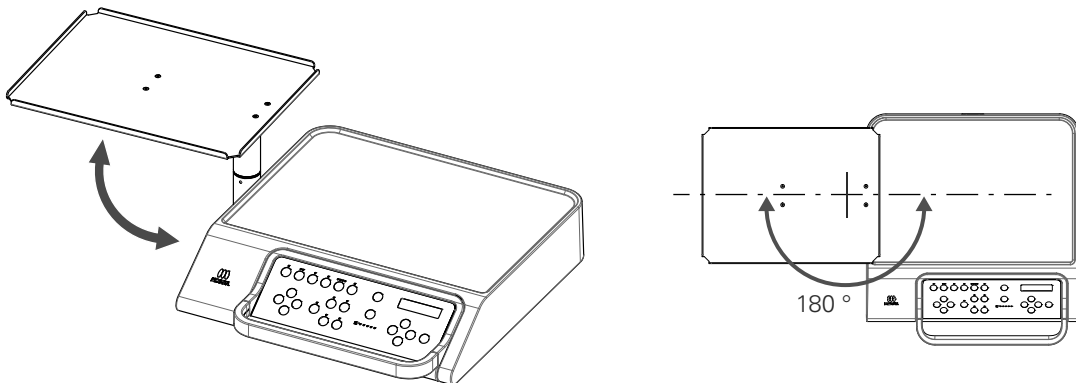

When the chair is lowered and the auxiliary table is loaded downward, the safety switch operates and the chair stops. Remove the load and try again.

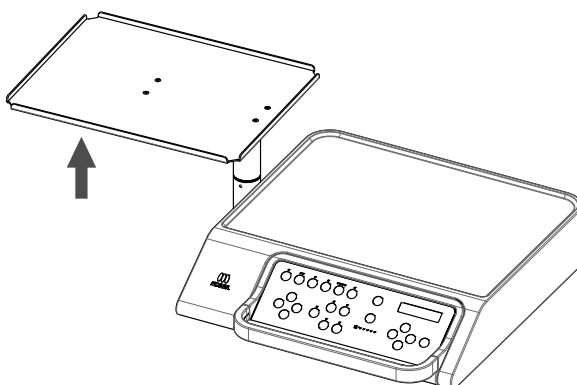

SAFETY SW
TRAY

4.5 Instrument Holder

| ⚠ CAUTION | |
|------------------|--|
| ! | When operating the chair, always be sure to operate the instrument holder and arm in a way which avoids the seat and backrest. <ul style="list-style-type: none"> • Damage and faults may occur if the chair is operated while the instrument holder and arm are over the seat or backrest. |
| | To alter the position of the instrument holder, slowly move the instrument holder while firmly holding the tray handle. <ul style="list-style-type: none"> • Holding and pulling the instrument portion and holder tip when done forcefully may cause damage and faults. |
| ⊘ | Do not apply a load of 10 N (1 kgf) or more to the assistant-side auxiliary tray. <ul style="list-style-type: none"> • This may cause damage/faults. |
| | Do not apply a load to the main tube (by pulling the tray by the main tube or by forcefully pulling the tube when wiping it). <ul style="list-style-type: none"> • This may cause air leaks/water leaks and damage/faults. |

4.5.1 Doctor-side Holder

| ⚠ CAUTION | |
|------------------|---|
| ⊘ | Do not forcefully pull or remove the main tube, roller, or holder cup from the holder. <ul style="list-style-type: none"> • Not following the correct procedure may result in damage or a fault. |

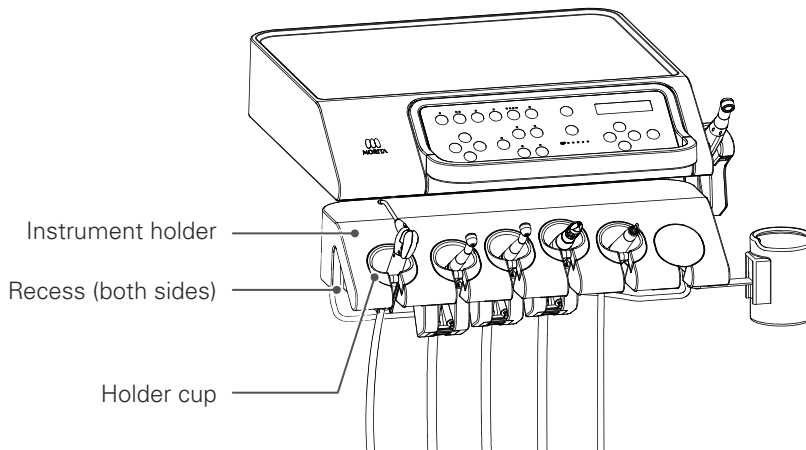

■ Doctor-side holder

Move the instrument holder horizontally.
 Move it by placing your fingers in the side recess and pulling gently.



4.5.2 Assistant-side Holder

⚠ CAUTION

| | |
|---|---|
|  | <p>Do not put heavy objects on the assistant-side arm and do not apply excessive force by performing sudden movement etc.</p> <p>Do not sit on the arm, rest your hands on it, or put your feet on it, etc.</p> <p>Do not forcibly insert the nozzle while the syringes are in the holder.</p> <ul style="list-style-type: none"> • This may result in accidental injury or a fault. |
|  | <p>When operating the assistant-side holder and arm, always ensure that it is safe.</p> <ol style="list-style-type: none"> ① Do not allow hands, parts of the body/baggage etc. to come close to the movable parts of the arm (grasp the arm, touch the base of the holder etc.) ② Do not allow the patient to touch it (mischievous pranks of children, leaning against it) ③ Do not place items/appliances that could impede movement into the range of the arm. ④ Do not behave in a way that could be considered dangerous ⑤ Do not operate in a situation that could be dangerous <ul style="list-style-type: none"> • Failure to check could result in injury, damage/faults. |

■ Assistant-side holder

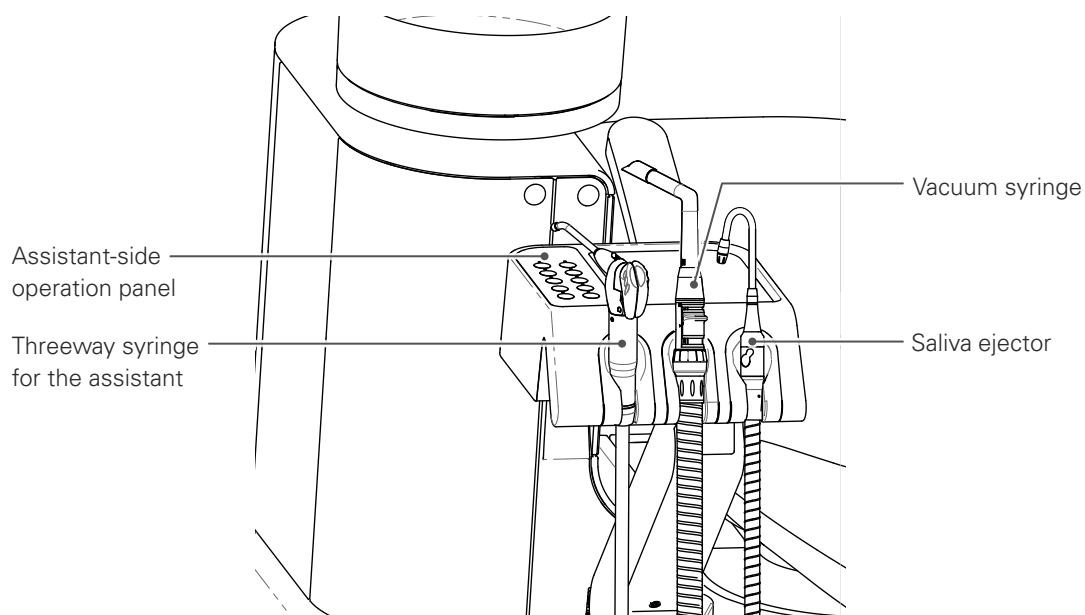

Arm Movable Range

The holder can be moved with the balance arm and it can be arranged depending on the type of treatment.

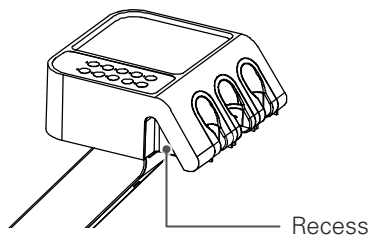
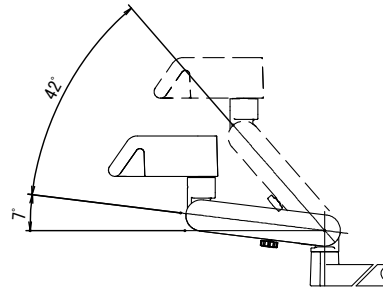
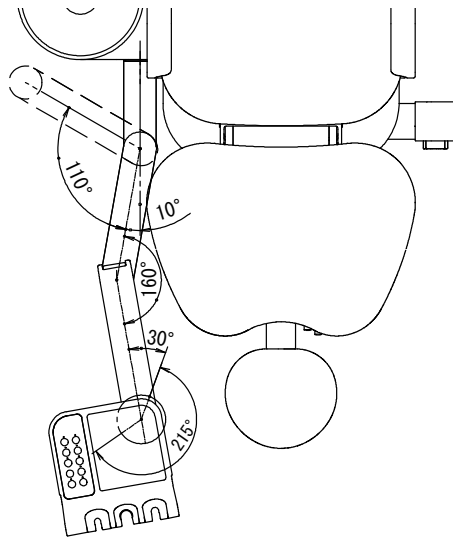

When moving the holder and arm, place your fingers in the hollow in the sides of the holder (both sides) and move it gently.

Fixing the Arm Angle

Adjust the angle of the balance arm and fix its position.

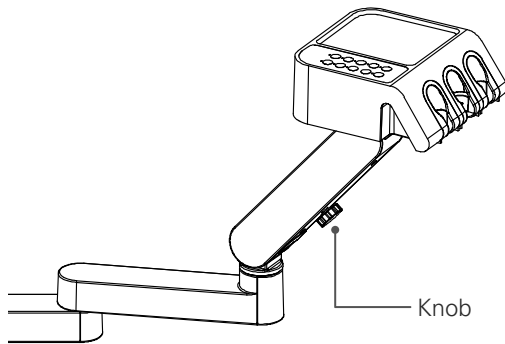

Adjust the angle of the balance arm and fix its position.

Loosen the knob on the arm, move the arm to the desired position, and tighten the knob to fix the arm angle.

To move the arm again, loosen the knob and move it.

If the movable arm has been fixed in a low position, the holder may jump upward when the knob is loosened. Always hold the holder before making the adjustment.

Take care not to loosen the knob too much. It can come off and allow structural parts to drop off.

If the knob has been tightened, do not forcibly move the balance arm. The internal mechanism may break.

Assistant-side Tray

CAUTION

Do not apply a load of 10 N (1 kgf) or more to the assistant-side auxiliary tray.

- Sudden dropping of the arm may cause a collision and damage/faults.



Do not place drug bottles, ethanol lamps (mainly liquids etc.) on the assistant-side auxiliary tray.

- There is a danger that the arm will drop during operation and cause an accident.

It may also cause discoloration of the appearance due to adhesion and cause a fault due to internal contamination.

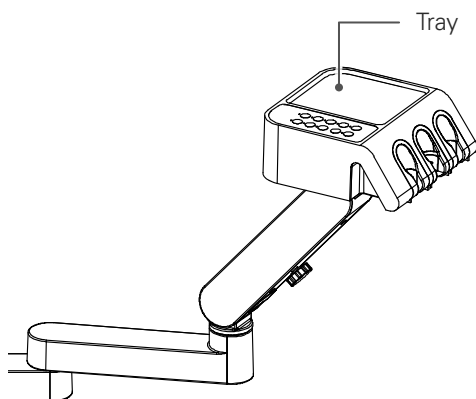

When using the tray, be careful not to interfere with the operation of the instrument.

Always be sure to fix the arm angle before placing objects on the tray.

4.6 Instruments

| ⚠ WARNING | |
|------------------|--|
| | <p>For how to connect and use the air turbine, micromotor, ultrasonic scaler etc., always follow the operation instructions supplied with the relevant product.</p> <ul style="list-style-type: none"> • Improper handling may cause accidents and faults due to unforeseen circumstances. |
| ! | <p>When putting instruments into the holders, do so gently and carefully. If an instrument is not put back securely, it may not be selected correctly.</p> <ul style="list-style-type: none"> • This may cause accidents/problems and faults. |
| | <p>If significant expansion occurs in the main tube while the air turbine is being used, immediately stop using it and check the state of the exhaust.</p> <ul style="list-style-type: none"> • If the exhaust tube ruptures or clogs, continued use may lead to expansion and rupture of the main tube, and an accident/fault may occur. |
| | <p>Be sure the handpiece bar has stopped rotating before putting the handpiece into the patient's mouth.</p> <ul style="list-style-type: none"> • There is the risk of injury. |
| ⊘ | <p>Do not bend the main tube while using instruments, especially when using the air turbine.</p> <ul style="list-style-type: none"> • If you continue use it while bent . This may lead to expansion and rupture of the main tube, causing an accident/ fault. |
| ⚠ CAUTION | |
| ! | <p>Pay careful attention when jetting air onto the gums of the patient, and promptly take appropriate action if an abnormality occurs.</p> <ul style="list-style-type: none"> • When air is used on the gingiva, complications such subcutaneous emphysema can occur. |
| ⊘ | <p>Keep heaters away from the device. Also, make sure that it is not exposed to warm air directly.</p> <ul style="list-style-type: none"> • Heat softens and expands the tube, causing breakage or other damage. |

4.6.1 Water Tank Option

Water for each instrument's water injection is supplied from the water tank attached to the pillar.
For the usage of the water tank, please operate according to the attached instruction manual.
However, adjust the pressure to 0.2MPa (200kPa) .

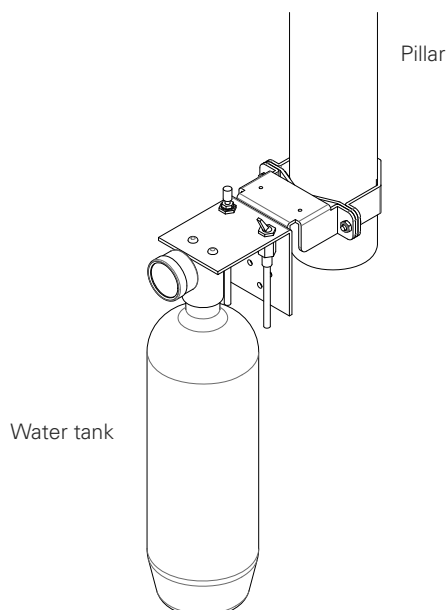

4.6.2 Water Supply Rate Adjustment

The instrument water supply rate can be adjusted. The air flow rate for the threeway syringe can also be adjusted.

■ Doctor-side instruments

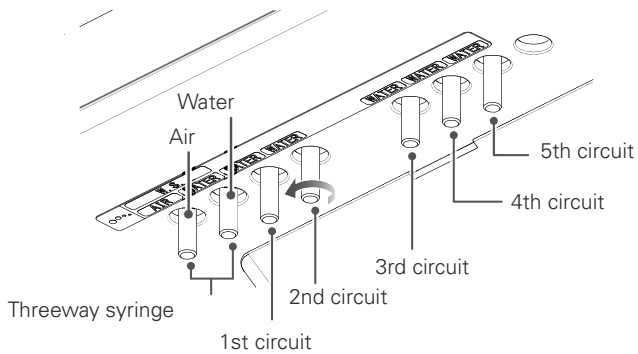
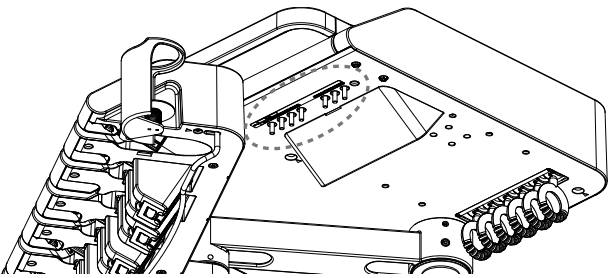

Adjust using the valve on the underside of the tray.
Turn in the direction of the arrow to increase the water flow rate and air flow rate.

■ Assistant-side threeway syringe

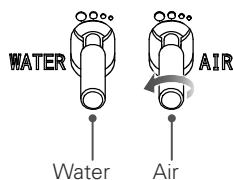
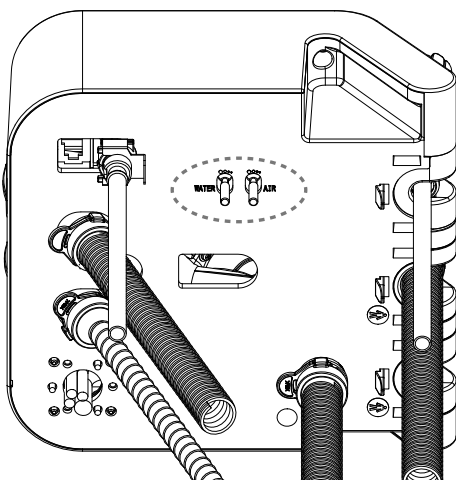

Adjust using the valve on the lower surface of the assistant-side holder.

Turn in the direction of the arrow to increase the water flow rate and air flow rate.

4.6.3 Foot Control Operation (extended function) Option

The foot control with extended functions enables you to perform the following operations while holding an instrument.

■ Switching Range

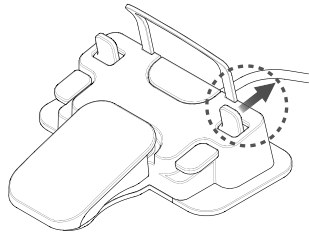

Operate the lever in the direction of the arrow.
Instrument range (UL, L, M, H) switchover.

- Micromotor
- Ultrasonic scaler

■ Instrument light ON/OFF

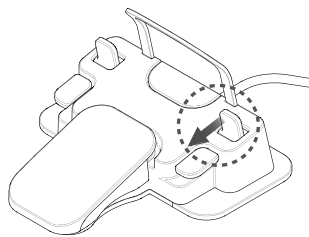

Operate the lever in the direction of the arrow.
Switches the instrument light ON/OFF and changes the illumination.
(OFF, ON, ON [BRIGHT])

■ Switching rotation direction

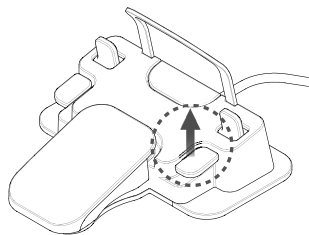

Operate the lever in the direction of the arrow.
Changes the direction of rotation of the micromotor.

■ Switching water flow

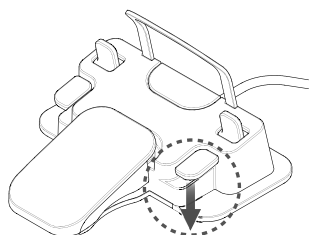

Operate the lever in the direction of the arrow.
Switches instrument water flow ON/OFF.

4.6.4 Air Turbine Handpiece

For details of how to handle the air turbine handpiece, always read the separate operation instructions.

■ Starting and Stopping Rotation

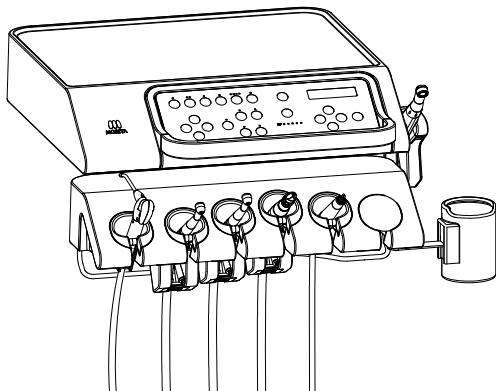

HS1

- ① Pick up the air turbine handpiece from the instrument holder.
At this point, the circuit of the instrument you pick up first takes priority.
Picking up another instrument will not change the circuit selection.

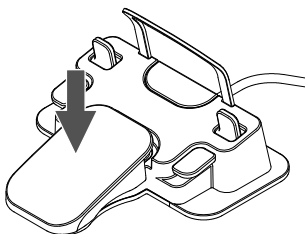

HS1



- ② Step on the foot control pedal to run the air turbine at a constant speed and release the pedal to stop.
The level bar on the panel will show the maximum level during rotation.
The LED on the variable speed/constant speed changeover switch lights up blue/orange.

Chair operation is not possible while the micrometer is running.



■ AI Catch Function

This is a function for supporting the weight of the tube the tube port to reduce the stress on the wrist while the handpiece is in use. Switching ON/OFF, AI catch timing (0-9.9 seconds), AI catch release timing (0-9.9 seconds) can be set.

Various Settings

- AI catch ON/OFF setting ☞ p. 96
- AI catch/timing delay period setting ☞ p. 96
- AI catch/release delay period setting ☞ p. 96

■ Clean air system Option

Prevents the suction effect that occurs when rotation of the air turbine stops, and prevents ingress of cutting debris, soiled waste etc. into the air circuit.

Expels a small amount of air for about 10 seconds when the air turbine stops.

■ Variable Speed Option

The rotation speed varies depending on how far the foot control pedal is pressed.

The range is switched in 3 steps (L, M, H) using the range changeover switch and it rotates at variable speed in each range.

An estimate of the maximum rotation speed for each range is displayed on the panel.

Because the rotation speed is varied by varying the air pressure, it may not exactly match the air turbine rotation speed.



■ Air Scaler Option

This is an air scaler that can be attached to the air turbine circuit.
Vibration can be performed using the same operations as for the air turbine.

■ Various Settings

Various settings and changes can be made.
For settings, refer to the following sections.

- Switching water flow ON/OFF ☞ p. 25
- Switching the light, illumination ON/OFF ☞ p. 25
- Setting the water injection timing ☞ pp. 94-95
- Switching between variable speed/constant speed ☞ p. 25
- Range changeover ☞ p. 25

4.6.5 Micromotor

⚠ CAUTION



Do not apply repeated sudden loads or lock the micromotor while it is rotating.
 • The micromotor may overheat and cause a fault.

For details of how to handle the micromotor, be sure to read the separate operation instructions.

■ Starting and Stopping Rotation

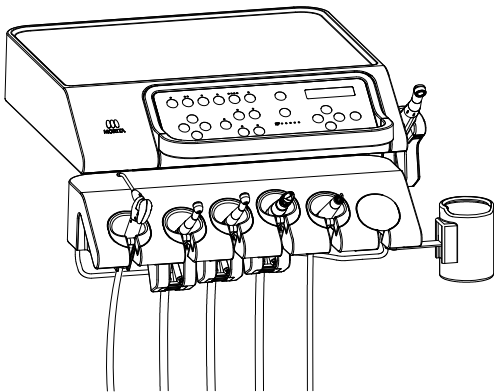

LS1

RANGE: UL **4.0 : 1**
3 0 0 rpm

- ① Pick up the micromotor from the instrument holder.
At this point, the circuit of the instrument you pick up first takes priority.
Picking up another instrument will not change the circuit selection.

- ② Screens showing the speed up ratio/speed reduction ratio of the attachment and the micromotor rotation speed are displayed.

- ③ Press the Enter key to change the ratio setting.
Press the Left/Right keys to change between speed up ratio/uniform speed/speed reduction ratio.
Select the ratio setting you wish to use.
Press the Enter key to confirm.

- ④ Step on the foot control pedal to start the micromotor and release the pedal to stop.

Chair operation is not possible while the micrometer is running.

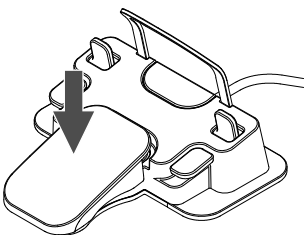

■ Speed Up Ratio/Speed Reduction Ratio Selection

Changes the speed up ratio/speed reduction ratio of the attachment.



RANGE: UL 4.0 : 1
3 0 0 rpm

① Press the Enter key to change the speed up ratio/speed reduction ratio. Use the Left/Right keys to select the speed up ratio or speed reduction ratio.

② Press the Enter key to confirm.

Changing the value of the speed up ratio and speed reduction ratio is carried out using the "Micromotor speed up/speed reduction ratio setting"  p. 93

■ Setting the Rotation Speed

An estimated rotation speed is displayed on the panel.

You can switch between 4 ranges (UL, L, M, H) using the range changeover switch and further adjust the speed within each range.

The upper limit of the rotation speed can be set for constant speed and variable speed.

The displayed rotation speed is an estimate of the micromotor speed calculated based on the speed up ratio/speed reduction ratio of the attachment and may not exactly match the actual rotation speed.

Constant Speed

Rotates at a constant speed when the foot control pedal is stepped on.

The settable upper limit speeds are as follows.

| Range | Rotation speed (min ⁻¹) |
|-------|-------------------------------------|
| UL | 300 |
| L | 5,000 |
| M | 20,000 |
| H | 40,000 |

Variable speed:

The rotation speed varies depending on how far the foot control pedal is pressed.

The available variable speeds are as follows.

| Range | Rotation speed (min ⁻¹) |
|-------|-------------------------------------|
| UL | 100-300 |
| L | 100-5,000 |
| M | 100-20,000 |
| H | 100-40,000 |

Setting the Rotation Speed

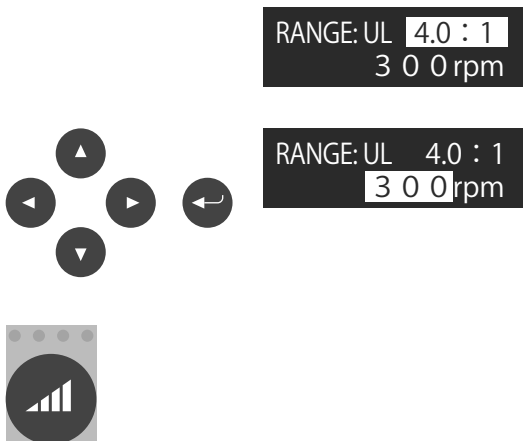

① Select the rotation speed display using the Left/Right keys.

② When the Enter key is pressed, you can change rotation speed. Increase/decrease the rotation speed using the Up/Down keys. It changes 10 times/minute for below 1000 and 100 times/min for 1000 or more. Holding down Up/Down keys changes the time in 50/min and 500/min units. Confirm with the Enter key. The rotation speed can be set for each range.

■ Chip air ON/OFF

Chip air ON/OFF can be set.
Can be set for each range.

The micromotor may become hot if chip air continues to be used while it is OFF. Usually use chip air while ON.

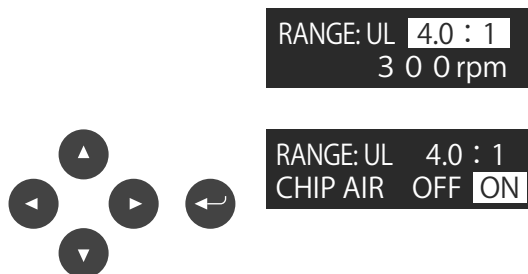

① The chip air ON/OFF setting screen is displayed using the Left/Right keys.

② Chip air ON/OFF can be changed using the Enter key. Select using the Left/Right keys and press the Enter key to confirm.

■ Various Settings

Various settings and changes can be made.
For settings, refer to the following sections.

- Switching water flow ON/OFF ☞ p. 25
- Switching the light, illumination ON/OFF ☞ p. 25
- Setting the water injection timing ☞ pp. 94-95
- Switching between variable speed/constant speed ☞ p. 25
- Switching rotation direction ☞ p. 25
- Range changeover ☞ p. 25

4.6.6 Threeway Syringe

⚠ WARNING



When using hot water, be sure to check that the temperature is correct before use.

- The temperature of the warmer may rise considerably due to overheating or the effects of external air temperature and accidents such as scalding and damage/faults may occur.

⚠ CAUTION



If hot water is not needed, turn the warmer switch OFF.

- Overheating of the heater may shorten the life of the tube or heater and lead to damage and faults.



Keep heaters such as fan heaters and oil heaters close to each other, or make sure that warm air does not hit them directly.

- Heat softens and expands the tube, causing breakage or other damage.

■ WS97

Operation

When the water lever and air lever are operated, water, air and spray will be emitted.

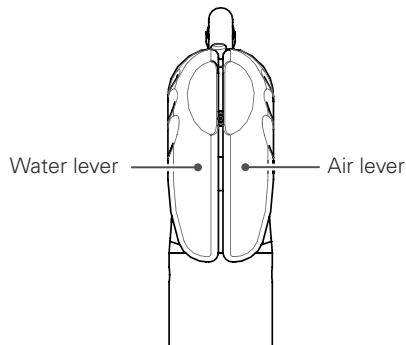

Water lever: emits water.

Air lever: emits air.

Water and air levers pressed together: emits a spray.

Removing and attaching the nozzle and syringe body

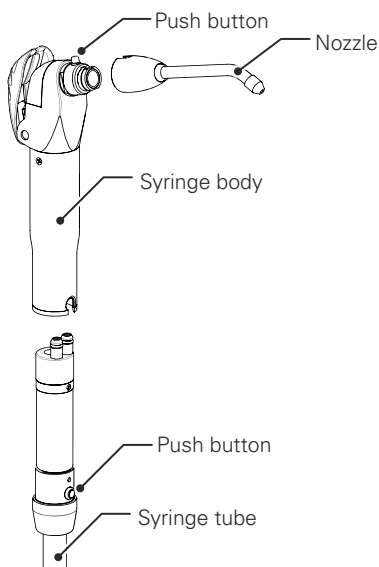

Both the nozzle and body can be autoclaved and removable.

Removing and attaching the nozzle

Hold down the push button for the syringe body and pull out the nozzle from the syringe body.

To reattach it, push it straight in until it clicks into place.

Connect the nozzle to the syringe body securely. It may unexpectedly pop out if it is not connected securely.

Removing and attaching the syringe body

Hold down the push button for the syringe tube and pull the syringe tube out of the syringe body.

To reattach it, push it straight in until it clicks into place.

Connect the syringe body to the syringe tube securely. It may unexpectedly pop out if it is not connected securely.

■ **WS10-O-LD** Option

Operation

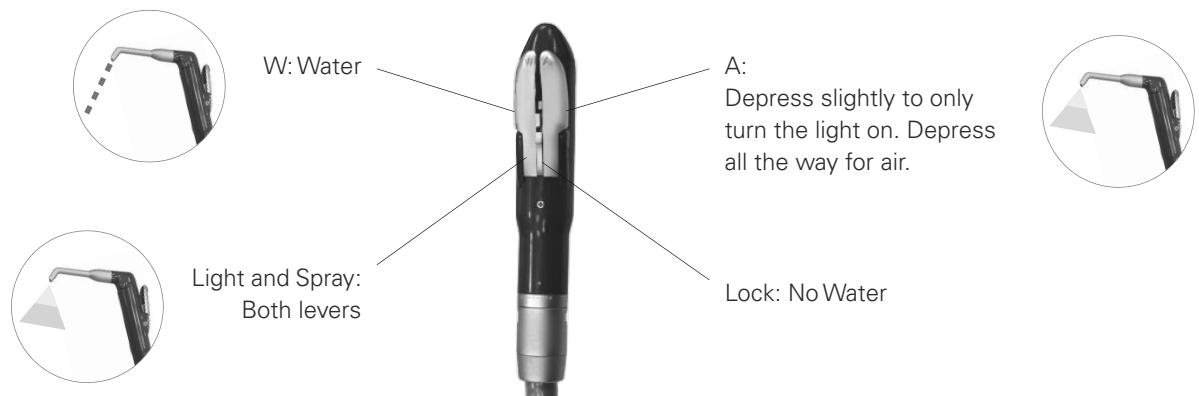

Always lock the water lever before putting the syringe away to prevent leaking.

Connection / removal of nozzle and syringe case

| ⚠ CAUTION | |
|------------------|--|
| ! | Make sure there is an audible click when putting the nozzle on the threeway syringe and that the nozzle is securely fixed to the syringe. |
| | Remember that the LED and its cover are extremely hot right after the LED has been turned off. Do not touch these parts; they could cause a burn. |
| | Make sure the threeway syringe case and body are securely attached to each other. Otherwise, the case could slip off when you take it out of its holder. |
| | If the nozzle gets plugged up with debris, it could be blown off the end of the syringe during use and injure someone. |

Removing and inserting the nozzle

Push the nozzle into the syringe or pull it out.

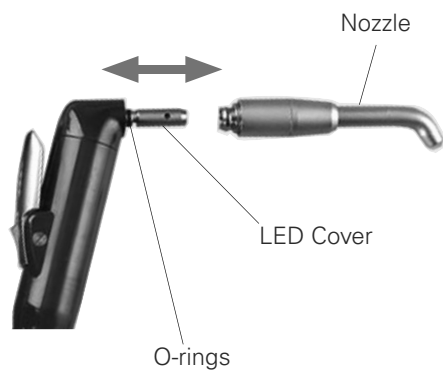

- A little water may come out of the threeway syringe when the air lever is pressed right after the nozzle has been attached. Press the air lever 2 or 3 times to expel all the water.
- Coat the O-rings with vaseline if it is hard to attach and remove.

Putting on the syringe case

Match the marks on the syringe case and the syringe body, and push them together until they click. Make sure the syringe case is securely connected.

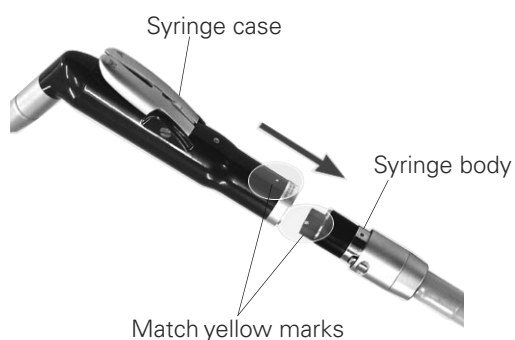

Taking off the syringe case

Press down on the indented part of the syringe tube connector and pull the syringe case off the syringe body.

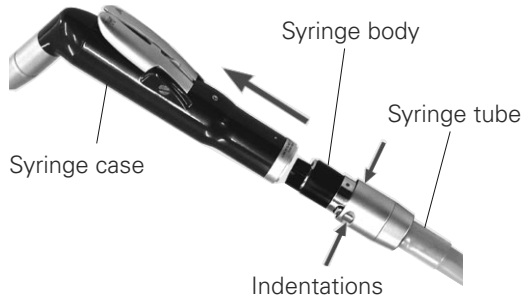

4.6.7 Vacuum Syringe

Suck out cutting debris and water from the oral cavity.

■ Vacuum syringe (VS110)

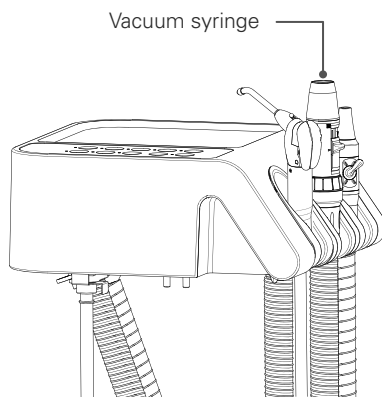

Starting and Stopping Suction

- ① Suction starts automatically when the vacuum syringe is picked up from the instrument holder.
Suction stops when it is placed in the instrument holder.
- ② Suction temporarily stops when the vacuum suction switch on the assistant operation panel is pressed during suction.
Press again to resume suction.

Even if it is placed in the instrument holder with the suction stopped, suction starts when the vacuum syringe is picked up from the holder again.

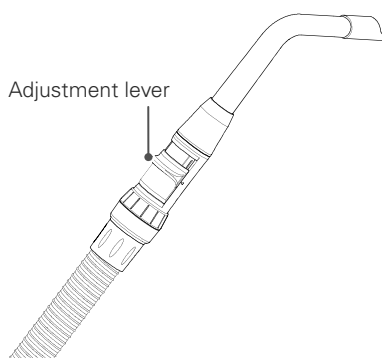

Suction Strength Adjustment

The suction rate changes when the adjustment lever is slid.

When wrapping the adjustment lever with plastic etc., avoid moisture oozing out under the effects of pressure during suction.

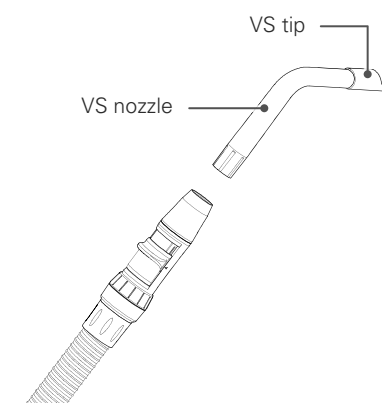

VS nozzle connection

Insert the VS tip firmly into the VS nozzle tip, and then insert it straight into the tip of the syringe.

Hold the syringe body firmly when inserting it.
An improper connection may result in damage.

If insertion of the VS nozzle or the VS tip is insufficient, it may disconnect during use.

The standard connection is a $\phi 16$ nozzle, but other nozzles with different diameters ($\phi 10$ or $\phi 11$) can be connected by replacing the tip of the syringe (conversion adapter **Option**).

■ Vacuum Syringe Rotary Type (VS110) Option

The direction of the tip of the syringe can be changed by rotating the base of the vacuum syringe.
Hold the syringe tube sides, rotate the tip and change the direction.

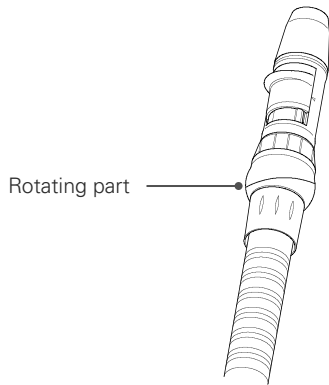

Hold the syringe tube sides, rotate the tip and change the direction.

4.6.8 Saliva Ejector

■ Saliva ejector (SE110)

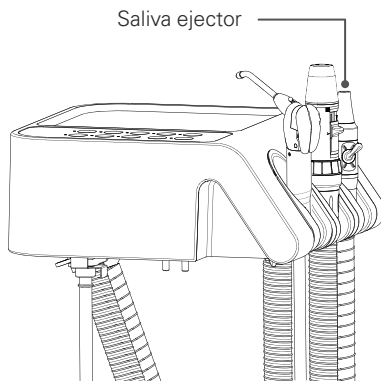

Starting and Stopping Suction

Suction starts automatically when the saliva ejector is picked up from the instrument holder.

Suction stops when it is placed in the instrument holder.

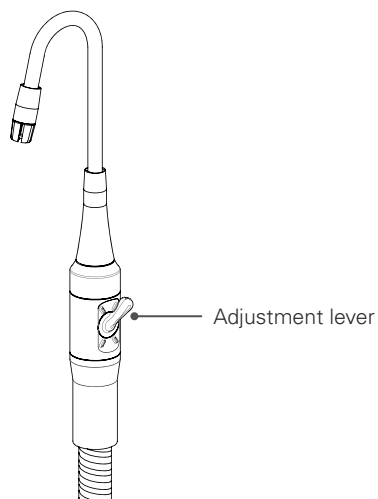

Suction Strength Adjustment

The suction strength changes when the adjustment lever is rotated.

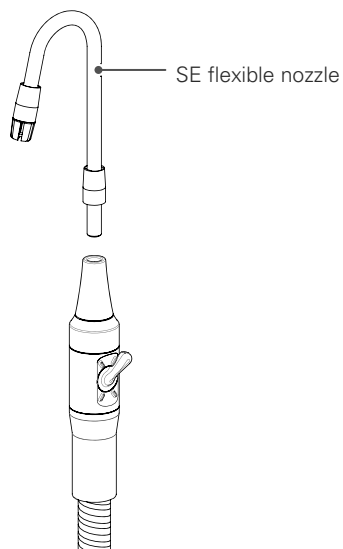

SE Flexible Nozzle Connection

Insert the SE flexible nozzle into the rubber part at the tip of the ejector. The SE flexible nozzle can be installed in any orientation.

If the SE flexible nozzle is bent strongly or repeatedly bent, the wire inside may break and there is a possibility that it may pierce the tube surface. Always check the state of the wire and replace it with a new one if it is damaged.

4.6.9 Ultrasonic Scaler (Newtron) Option

For details of how to handle the ultrasonic scaler, always read the separate operation instructions.

■ Attaching the syringe

LED without light

With LED Light

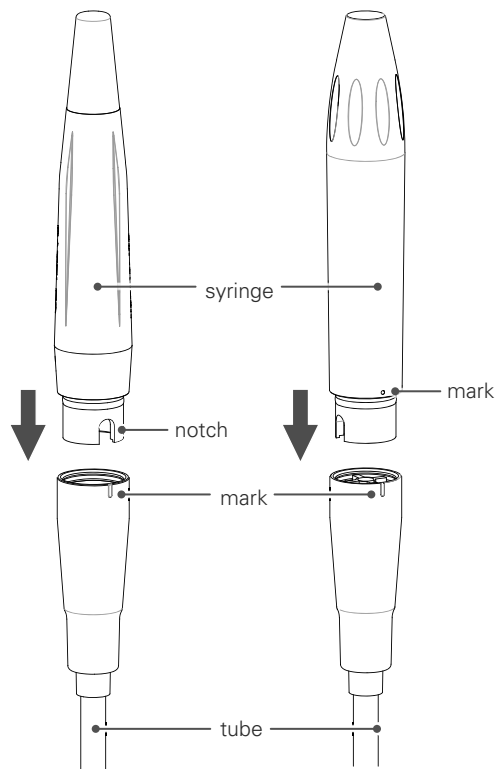

LED without light

Align the notch on the syringe side with the mark on the tube side and insert the syringe.

With LED Light

Align the syringe side mark with the tube side mark and insert the syringe.

Please connect the syringe and tube reliably.
It may unexpectedly deviate if it is not securely connected.

■ Vibration and Stopping

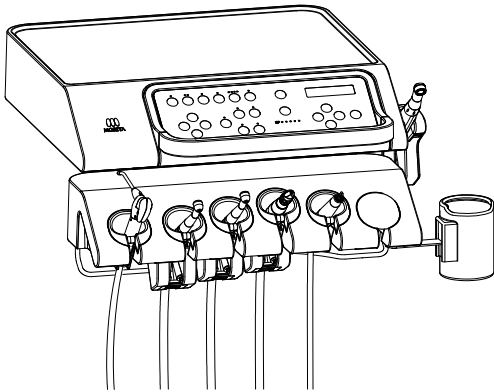

SC

RANGE: PERIO
POWER: P 8. 5

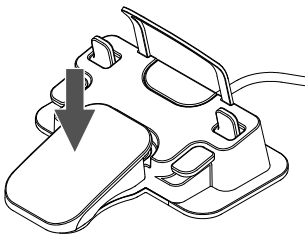

POWER: P 8. 5
■■■■■■■■■□

- ① Pick up the ultrasonic scaler from the instrument holder.
At this point, the circuit of the instrument you pick up first takes priority.
Picking up another instrument will not change the circuit selection.

- ② The screen of the selected range display is displayed
Example: PERIO
- ③ Changes the range.
Use the range changeover switch to switch between "PERIO", "ENDO" and "SCALING".
- ④ Change the power value as necessary.
Press the Enter key to select the power value. Change it using the Up/Down keys.
Press the Enter key to confirm.
It can be changed from 0.5-10.0 in increments of 0.5 for each range.

- ⑤ Step on the foot control to start vibration.
The panel display becomes the power bar display.
The power value can be changed during vibration using the Up/Down keys.
Take your foot off the pedal to stop the vibration.

During vibration, the chair cannot be operated.

■ Power Adjustment

The power value can be changed for each range.

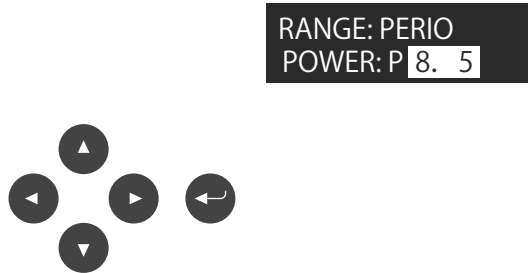

When picked up

- ① Press the Enter key to change the power value using the range display screen.
Change the power value using the Up/Down keys.
The power value can be changed from 0.5-10.0 in increments of 0.5.

- ② Press the Enter key to confirm.



During vibration

Although you can change power value during vibration, the power itself will not change.



The power changes when the foot control pedal is stepped on again.

- ① When the power bar is displayed during vibration, press the Enter key to change the power value.
Change the power value using the Up/Down keys.
The power value can be changed from 0.5-10.0 in increments of 0.5.

- ② Press the Enter key to confirm.

■ Various Settings

Various settings and changes can be made.
For settings, refer to the following sections.

- Switching water flow ON/OFF  p. 25
- Switching the light, illumination ON/OFF  p. 25
- Scaler one-touch mode  p. 92
(selecting continuous vibration or pedal synchronization)

4.6.10 Ultrasonic Scaler (Solfy) Option

For details of how to handle the ultrasonic scaler, always read the separate operation instructions.

■ Vibration and Stopping

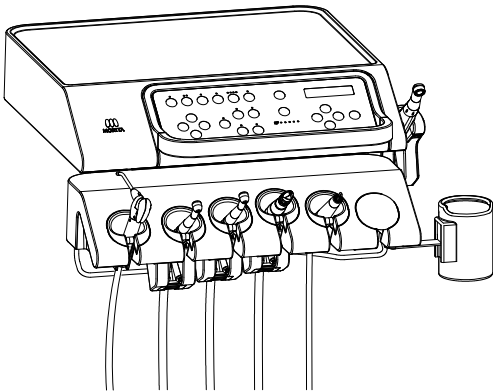

- ① Pick up the ultrasonic scaler from the instrument holder.
At this point, the circuit of the instrument you pick up first takes priority.
Picking up another instrument will not change the circuit selection.

SC

RANGE: SCALING
POWER: S 25 NORMAL

- ② The scaler selection screen is displayed.

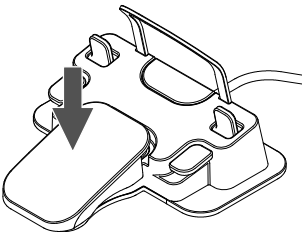

- ③ Step on the pedal on the foot control to start vibration.
The panel display shows the power bar.
Take your foot off the pedal to stop the vibration.
During vibration, the chair cannot be operated.

■ Changing the Range

Changes the range.



RANGE: SCALING
POWER: S 25 NORMAL

Press the range changeover key to toggle between "PERIO", "ENDO", "SCALING" and "BOOST" in this order.

■ Changing the Vibration Mode

The vibration mode can be changed for each range.

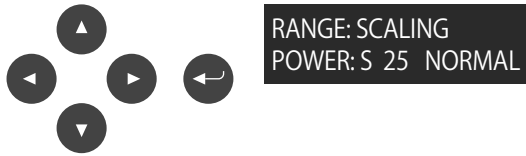

① With the scaler in hand, press the Left/Right keys, to toggle between “Normal Mode (NORMAL);” “Soft Mode (SOFT)” and “OFF”:

“Normal Mode”: Constant power is maintained to allow effective removal of calculi etc.

“Soft Mode”: The vibrations soften according to the tip force applied to the tooth to allow gentle removal of the calculi etc.

“OFF”: The tip does not vibrate.

■ Power Adjustment

You can change the power level in each range.

| Range | Power Setting Range |
|---------|---------------------|
| PERIO | 0-10 NOTE 1 |
| ENDO | 0-15 NOTE 1 |
| SCALING | 0-25 |
| BOOST | 0-25 |

NOTE 1: When changing the range, if you hold down the Up key for more than 3 seconds, the power value can be temporarily changed beyond the upper limit, up to a maximum of 25. Press the Enter key to confirm. However, the value is not memorized and it returns to the original value when the power of the dental treatment unit is turned off.

When picked up

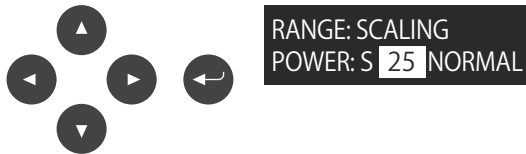

① Press the Enter key on the pick up screen.

② Press the Up/Down keys to change the power value.
(When 0 is selected, the scaler does not vibrate)

③ Press the Enter key to confirm.

During vibration



Although you can change the numerical power value during vibration, the power itself will not change.

The power will change when you step on the foot control pedal again.

① When the power bar is displayed during oscillation, press the Enter key.

② Change the power value using the Up/Down keys.
(When 0 is selected, the scaler does not vibrate)

② Press the Enter key to confirm.

■ Various Settings

Various settings and changes can be made.

For settings, refer to the following sections.

- Switching water flow ON/OFF 4 ☞ p. 25
- Switching the light, illumination ON/OFF ☞ p. 25
- Scaler one-touch mode ☞ p. 92
(selecting continuous vibration or pedal synchronization)

4.7 Unit

| | |
|------------------|---|
| ⚠ WARNING | |
| ⊘ | Do not lean on the unit or apply excessive load. Do not push the housing at the lower part of the unit or touch it while operating the chair. |
| | <ul style="list-style-type: none"> • This may cause damage/faults due to unforeseen circumstances. |
| ⊘ | Do not open the unit door while operating the seat/backrest. |
| | <ul style="list-style-type: none"> • This may cause damage/faults due to unforeseen circumstances. |
| ⚠ CAUTION | |
| ! | Allow sufficient space when opening the unit door. |
| | Open and close the door within a 90° range. <ul style="list-style-type: none"> • If the door is opened by force, damage to the door or its surroundings may occur, or it may cause damage/fault. |

4.7.1 Part Names

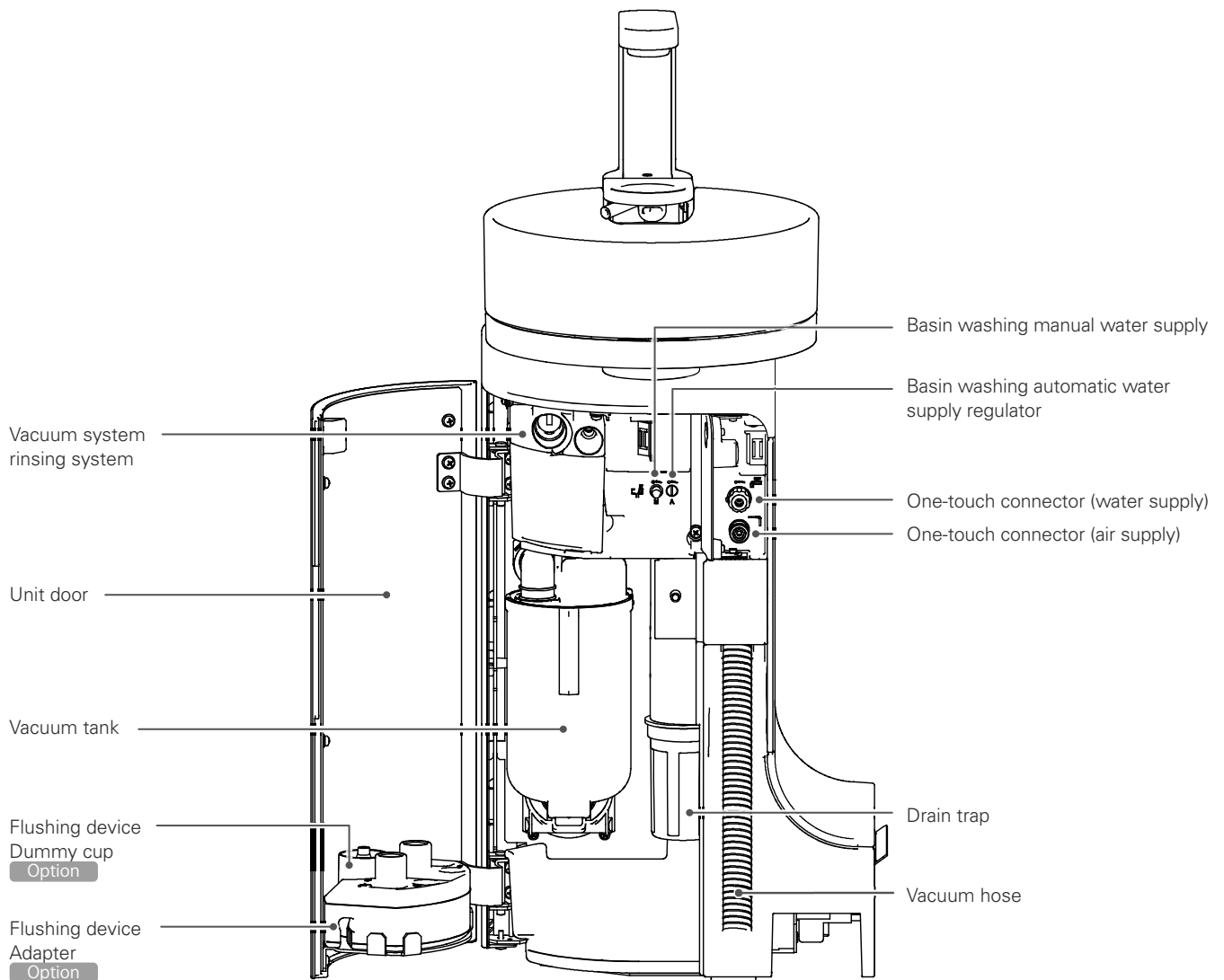

■ Opening and Closing the Unit Door

Open the unit door to carry out maintenance.

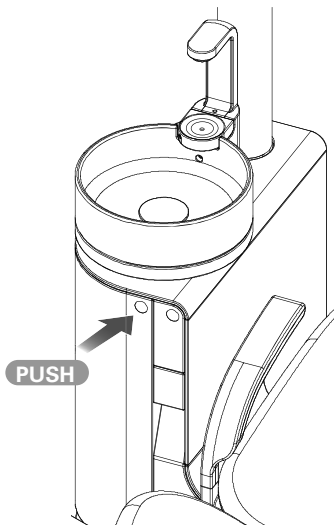

Push circular mark to open the unit door.
Open the door about 90°.

When closing the unit door, push the circular mark again until you hear a click.

4.7.2 Warmer

CAUTION



When the warmer is ON, always be sure to check the temperature of the hot water before use. If the warmer is not needed, turn the switch OFF.

- Scalding due to high temperature and damage/faults due to heater overheating may occur.

The water flow to each instrument and the cup water supply temperature from the automatic filler can be set by operating the warmer.

Warm water temperature setting

Switch or OFF the water temperature of the warmer using the common settings. The water temperature can be set in 3 stages(L, M, H)

 p. 87

- ① Switching the setting to L, M, or H activates the internal heater. It becomes warm water after a certain period of time. (The time it takes to become warm water depends on the temperature and water temperature.)
- ② Check the water temperature of the cup water supply and the three-way syringe before use.
Warm water may vary depending on where it is supplied. Check the temperature enough where warm water is needed.

4.7.3 One-touch Connectors (water supply/air supply)

⚠ CAUTION



Be sure to securely connect the one-touch joints (water supply joint/air supply joint) to the one-touch connector (water supply connector/air supply connector).

- An inadequate connection may cause a water leak/air leak/joint disconnection.

The water supply or air can be taken from the unit panel.

To take supply from the one-touch connectors, use a one-touch joint (water supply joint/air supply joint). Option

■ Opening and Closing the One-touch Connector Door

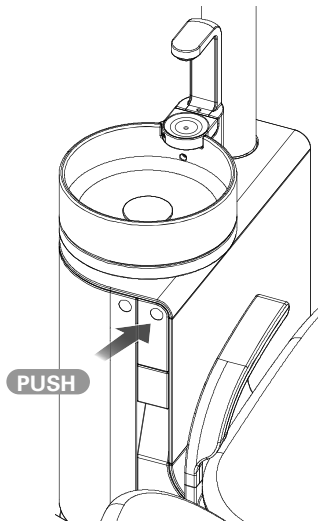

Push the one-touch fitting door circular mark to open the door.
Open the door about 90°.

When closing the door, push the circular marker again until a click is heard.

■ Water supply connector

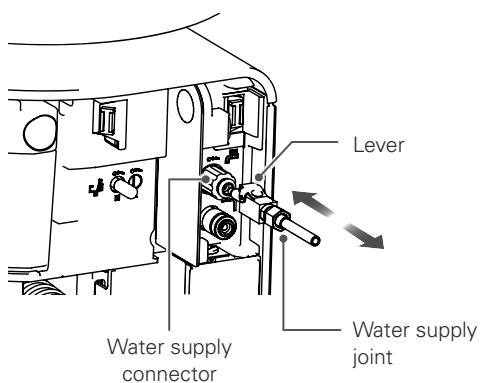

Water supply joint connector

Insert the water supply joint into the water supply connector in the panel.
Push it in until it clicks.

Water Supply Joint Removal

Pull the joint while pressing the water supply joint lever.

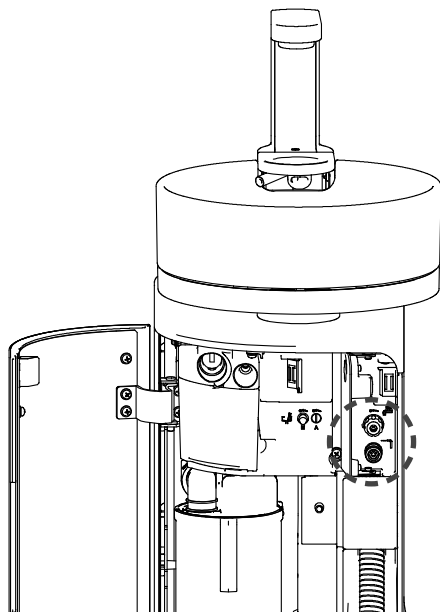

Water supply rate adjustment

The water supply connectors themselves are the adjustment knobs to control the water supply rate.
Turn the knob to adjust the water supply rate.

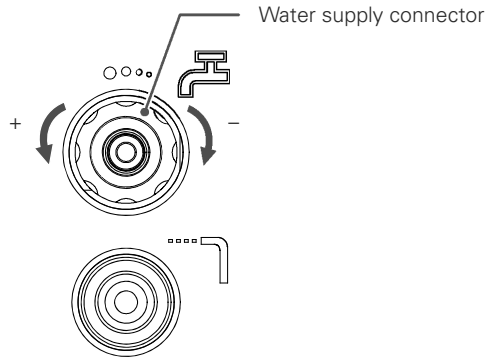

■ Air supply connector

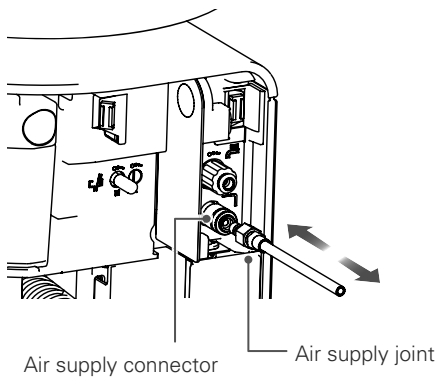

Air Supply Joint Connection

Insert the air supply joint into the air supply connector on the panel. Push it in until it clicks.

The supply pressure depends on the pressure of the air supplied to the chair unit.

The pressure of the air supply connector cannot be changed.

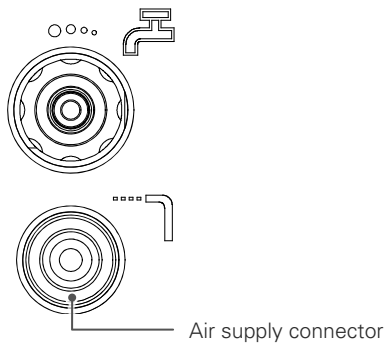

Air Supply Joint Removal

Slide the outer ring of the air supply joint backward and remove the air supply joint.

Hold the air supply joint firmly when removing it. The air supply joint may fly out quickly due to the air pressure.

The O-ring inside the water supply connector can wear out, so apply Vaseline to the tip of the air supply joint at least once a month.

4.8 Basin

4.8.1 Basic Operation

| ⚠ WARNING | |
|------------------|---|
| ! | <p>Let the basin rotate only when gargling.</p> <p>Avoid dangerous behavior such as the mischievous pranks of children, rough operation, leaning and putting your hands on it, and always check that it is safe.</p> <ul style="list-style-type: none"> • Accidents such as the pinching of fingers and falling may occur. |
| ⚠ CAUTION | |
| ⊘ | <p>Do not subject the basin and surroundings to excessive impacts.</p> <p>Do not strongly scratch the basin surface or the basin unit surface and do not hit it with hard or sharp objects.</p> <ul style="list-style-type: none"> • This may cause damage and injury. |
| | <p>Do not expose the basin to strongly colored chemicals over a long period.</p> <p>If chemicals do adhere, flush away with running water immediately and wipe with a sponge or the like.</p> <ul style="list-style-type: none"> • Color may remain. |
| | <p>Do not run hot water into the basin.</p> <ul style="list-style-type: none"> • This may cause a fault. |
| ! | <p>If there are abnormalities such as cracks, chipping, etc. in the basin, stop using it and immediately request a replacement.</p> <ul style="list-style-type: none"> • If use of the unit is continued with an abnormality, accidents such as injuries may occur. |

■ Rotating the Basin

Move the basin to the gargle position so that gargling is easy.
The movable range is about 80°.

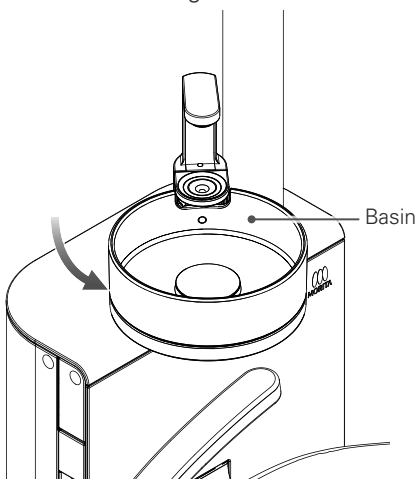

Manual Rotation of the Basin

Swivel the basin manually.
Hold the lower part of the basin and slowly move it.
Return the basin to its original position when chair operation is performed.
When the basin is moving, chair operations other than descent are not possible.

Electrically Operated Basin Option

- ① Automatic Rotation of the Basin
After the chair moves to the gargle position (soft memory), the basin automatically moves to the gargle position.
- ② Automatic return of the Basin
If the basin is in the gargle position during automatic operation of the chair, automatic operation of the chair will start after the basin automatically returns to its original position.

■ Automatic Rinsing of the Basin

This operates in conjunction with the cup water supply, with water being supplied automatically to the basin for rinsing. After supplying water to the cup, water is supplied to the basin and will stop after a certain time.

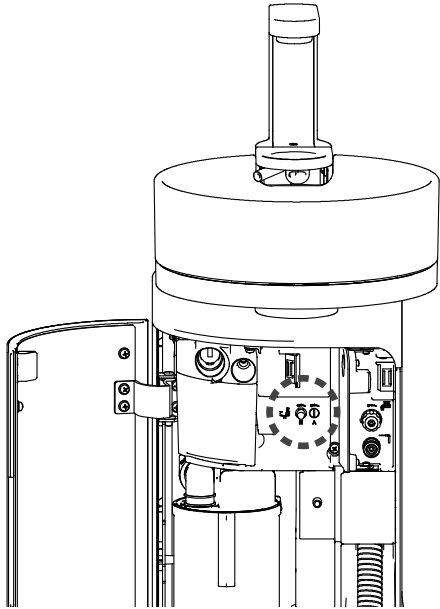

Setting the flow rate of the water for automatic rinsing

The flow rate of the water for automatic rinsing can be set. Turn the automatic rinsing water supply valve on the unit panel with a flat-head screwdriver to adjust the flow.

Automatic rinsing water supply valve

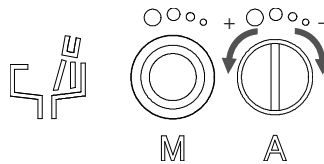

■ Basin Manual Water Supply

If the bowl becomes dirty and if water is continually supplied, supply water to the basin manually as necessary. The supply rate can be adjusted with manual water supply valve.

Manual water supply valve

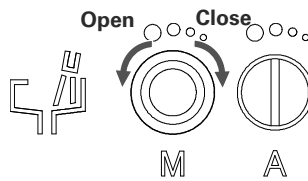

4.8.2 Cup Water Supply

⚠ WARNING

| | |
|---|--|
| ⊘ | Do not subject the water supply device to excessive loads or impacts, such as by grasping the automatic filler. Do not subject the device to excessive loads, forcibly disassemble it, or pour water over it. |
| | <ul style="list-style-type: none"> • This may cause damage/water leak/faults. |
| ! | Do not use the water supply device with the bowl washing nozzle removed. |
| | <ul style="list-style-type: none"> • The water for bowl washing will spout upward. |
| ! | If the sensor is dirty, wipe it with a dry cloth etc. |
| | <ul style="list-style-type: none"> • The automatic filler may not work properly. |

■ Automatic water supply

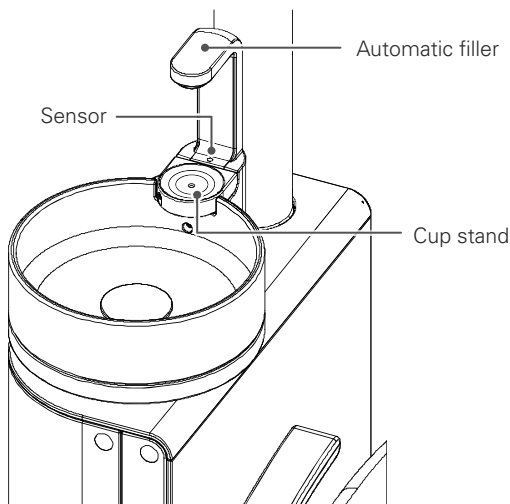

Operation

When a cup (made of paper or metal) is placed on the cup stand, a sensor senses the cup and water is automatically supplied.

The water level in the cup is detected and water is supplied to the set position.

If a cup filled to the set position is again placed on the cup stand, water will be supplied momentarily. This does not indicate a fault abnormal.

Materials that transmit light such as transparent glass cups and semi-translucent plastic cups cannot be used because the sensor does not react correctly.

To prevent malfunctions, there is a time difference of about 0.5 seconds from between sensing of the cup by the sensor and supply of water. Place the cup gently.

■ Manual water supply





Water is supplied while pressing the cup water supply switch (assistant-side operation panel).

Always be sure to operate the switch with the cup in position. If the cup is not in position, water will be spilled.

4.9 Operating Light

For details of how to handle the operating light, always refer to the separate operation instructions.

|  WARNING | |
|--|--|
|  | <p>Be careful that the light arm does not hit the patient or surroundings during lighting operations or when the chair moves.</p> <ul style="list-style-type: none"> • This could result in accident or injury.. |
|  | <p>Do not subject the light (head, arm etc.) to excessive impacts or vibration.</p> <p>Do not let moisture adhere to the light. If the light gets wet, turn the main switch on the main unit OFF and wipe the light with a dry cloth etc. In this case, do not use the light until it is dry enough.</p> <ul style="list-style-type: none"> • Accidents such as injury and damage/faults may occur. |

4.9.1 Basic Operation

■ ON/OFF Operation



Switch operation

Press the operating light ON/OFF switch on the operation panel to turn the light ON/OFF.

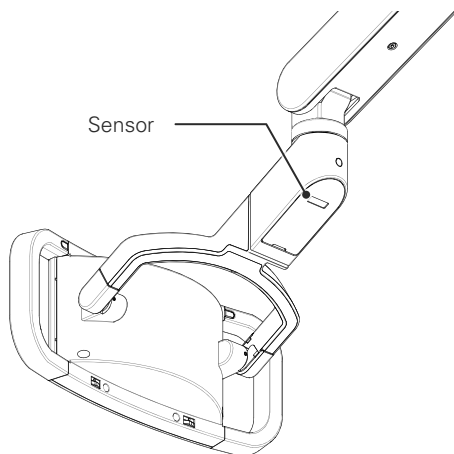

Touchless Sensor Option

When a hand is held over the sensor, the light turns ON/OFF.
(The sensing distance of the sensor is about 100mm in the direction of the sensor)

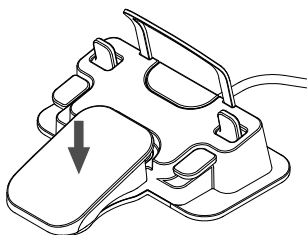

ON/OFF Using the Foot Control

The light can be switched ON/OFF by stepping on the foot pedal (over 2 seconds) while the doctor-side instruments (excluding the threeway syringe) are in the holders.

The light goes ON/OFF each time the foot pedal is stepped on.



■ Range Selection

There are 4 illumination ranges that are used by switching over.
The range changes each time the range changeover switch is pressed.

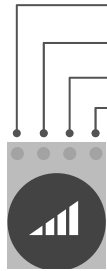

Switching Range

When the instruments are in their holders, the range changes each time the range changeover switch is pressed.

| Light display (green light comes on) | Range |
|--|-------|
|  R L M H | R |
|  R L M H | L |
|  R L M H | M |
| R L M H | H |

4.9.2 Setting

■ Adjusting Illumination in Each Range

The illumination in each range can be adjusted (excluding the R range).

(Maximum illumination: 30,000 Lx [at H range maximum adjustment])

Refer to various settings in "Operating Light Illumination Setting" for the adjustment method.

☞ p. 82

■ Interlock settings

Automatic interlock settings

Turn ON/OFF the operating light together with chair automatic operation (AUTO 1, AUTO 2, reset, soft memory).

The factory settings are as follows. Change the settings as necessary.

☞ p. 88

| Automatic Operation | Light |
|--|-------|
| AUTO 1/AUTO 2 | ON |
| Reset | OFF |
| Soft memory (gargle position movement) | OFF |
| Soft memory (return) | ON |

Instrument Link Settings

The operating light turns ON/OFF in conjunction with picking up an instrument.

☞ p. 89

4.10 Other Settings

Various settings are made using each operation switch, or panel display and manual operation switch.



Automatic switch
Example: Countdown timer



Panel display
Example: instrument lock



Manual operation switch

4.10.1 Countdown Timer

The digital countdown timer can be used.

■ Set the time on the timer

Up to 6 patterns can be set on the timer.

Times up to a maximum of 59 minutes 59 seconds can be set.



① Press the countdown timer switch.

The panel display becomes the countdown timer selection display.
Select 1-6 using the Left/Right keys to set the respective times.

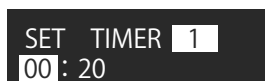
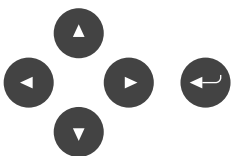

② Sets the time of the selected number.

Pressing the Enter key shows the settings screen.

Minutes and seconds are selected using the Left/Right keys.

The time is set using the Up/Down keys. (Minutes: 1 minute unit, seconds: 1 second unit)

Holding down the key increases or decreases the time in 5 minute and 5 second units.

■ Starting Countdown



① Press the Enter key.



② Countdown starts, and an alarm sounds when the time reaches zero. The alarm sounds for about 15 seconds then stops. Press the Enter key to interrupt countdown or to stop the alarm. At this time, the display returns to display the set time.

NOTE: If an instrument is picked up during countdown, the display switches to the pick up screen but the countdown continues.

4.10.2 Display while Instruments are in their Holders

With the instrument in its holder, select the item to be set using the Up/Down keys.

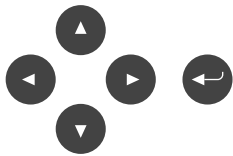

OPERATOR 1

- ① From the display screen for operator number, use the Up/Down keys to switch to the various settings screens.

HP LOCK
2 3 4 5 6

- ② Use the Up/Down keys to display the screen showing the item to be set. Make desired settings. Example: instrument lock

COMMON SETTINGS
SET

- ③ Common Settings
Make settings common to all operators.

USER SETTINGS
SET

- ④ User settings
Perform individual operator settings.

Switching Operator Number

A maximum of 5 patterns can be registered for various settings such as instrument setting and user setting.



Operator changeover switch

The operator changes when the operator changeover switch is pressed.

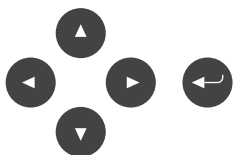

OPERATOR 1
1 2 3 4 5

Changeover using the Enter key and Up/Down/Left/Right keys.

- ① Press the Enter key.
The selected operator No. blinks.
- ② Move the blinking cursor to the operator No. you wish to select using the Left/Right keys.
- ③ At desired operator No, press the Enter key to select.
- ④ Next, configure the settings for each operator.

Instrument lock

Pauses a specific doctor-side instrument circuit (HP) temporarily.
Used when an instrument is removed etc.
Locked circuits are in an unusable state and will not respond to a pickup.



① Select the operator using the operator changeover switch.

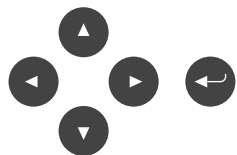

② Display the HP LOCK selection screen using the Up/Down keys.



③ Press the Enter key switch to changeover to the edit screen.
Select the HP LOCK circuit using the Left/Right keys. The selected circuit is highlighted (blinks). Switch ON/OFF using the Enter key.
The HP light on the panel display for the locked circuit blinks green.



④ To confirm, press the Enter key for 2 seconds or more.
Select other circuits with the Left/Right keys to make similar settings.

Operating light illumination setting

The illumination of each range (R, L, M, H) can be set (excluding R). Sets the illumination of the currently selected range.



① Display the illumination setting screen showing the currently selected range.



② Press the Enter key to make the level bar blink.

③ Use the Left/Right keys to increase/decrease the level.
Note that each range has an upper limit and settings beyond the upper limit cannot be made.

| Range | Variable level setting |
|-------|------------------------|
| R | 1 (cannot be changed) |
| L | 1-4 |
| M | 1-6 |
| H | 1-8 |

④ Press the Enter key to confirm.

■ Common Settings

Makes common settings for each operator.



① Display the common settings screen.

② Press the Enter key to display the common settings screen.
From this point, refer to “4.14.2 Common Settings” to make desired settings.

■ Individual user settings

Perform individual operator settings.



① Display the individual user settings screen.

② Press the Enter key to displays the individual user settings screen.
From this point, refer to “4.14.2 Individual User Settings” to make desired settings.

4.10.3 Common Settings

Make settings common to all operators.

Make settings according to the following procedure. The instruments must be in their holders.

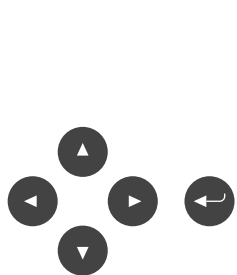

Operator screen

① Display the COMMON SETTINGS screen using the Up/Down keys and press the Enter key.

② Use the Up/Down keys to display the screen showing the item to be set. Make desired settings. Example: CHAIR SPEED selection

③ After completing the settings, display the RETURN MAIN MENU screen using the Up/Down keys and press the Enter key. This completes the settings and returns the display to the operator screen.

■ Chair Speed Switching

Chair speed switching offers two basic chair speeds NORMAL (standard) and SLOW. Within each of the NORMAL and SLOW options, you can make further adjustments to the CHAIR SPEED setting.

NORMAL (standard) settings

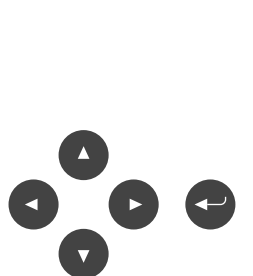

CH SPEED NORMAL
H

CH SPEED NORMAL
UL L M H

Select CHAIR SPEED (UL, L, M or H) using the Left/Right keys and press the Enter key to make the setting.

SLOW settings

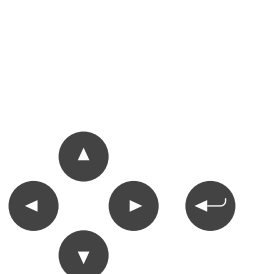

CH SPEED SLOW
H

CH SPEED SLOW
UL L M H

Select CHAIR SPEED (UL, L, M or H) using the Left/Right keys and press the Enter key to make the setting.

■ Automatic power OFF

When the main unit has not been used for a certain period of time, the power supply turns OFF automatically for safety (the factory setting is 120 minutes).

The following condition arises in during power save.

- the operating light goes off
- the display goes off
- chair operation input is not possible
- the water supply stops (the water supply solenoid valve closes)

Power save mode is canceled by one of the following operations.

- pressing the automatic operation switch on the doctor-side operation panel or assistant-side operation panel
- stepping on the foot pedal
- picking up a doctor-side instrument

The time until power save (60 or 120 minutes) and OFF (continuous electricity supply) can be selected.

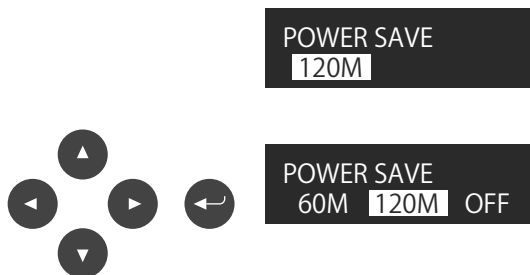

Select the automatic power OFF time or no setting using the Left/Right keys and press the Enter key.

■ Water supply rate for the cup water supply

Setting the water supply rate for the cup water supply



Select (highlight) using the Left/Right keys and press the Enter key to set the desired water volume. Water supply OFF can also be set.

■ Warm water temperature setting

Set the water temperature of the wamer or OFF.



[factory setting: OFF]
Set the water temperature (L, M, H) or OFF using the Left/Right keys and press the Enter key.

■ Vacuum System Rinsing Settings

For the rinsing method of the vacuum circuit, select whether to rinse with water or cleanser.

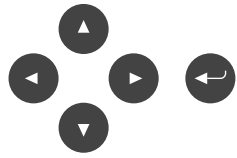

EV CLEAN MODE
WATER

Press the Enter key.

EV CLEAN MODE
WATER | CLEANSER

Select (highlight) water or cleanser using the Left/Right keys and press the Enter key.

■ Foot control link setting

Allocates operations to the foot control pedal.

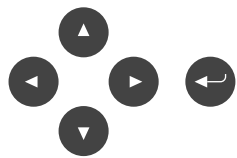

FOOT CONTRL LINK
LIGHT

① Press the Enter key.

FOOT CONTRL LINK
NO LIGHT

② Select using the Left/Right keys.

NO: Chair operations not allocated to pedal.

LIGHT: Step on the pedal for 2 seconds or more while the instruments are in their holders to turn on the operating light.

Step on the pedal again for 2 seconds or more to turn off.

Press the Enter key to confirm.

4.10.4 Individual User Settings

Makes common settings.

Make settings according to the following procedure. The instruments must be in their holders.

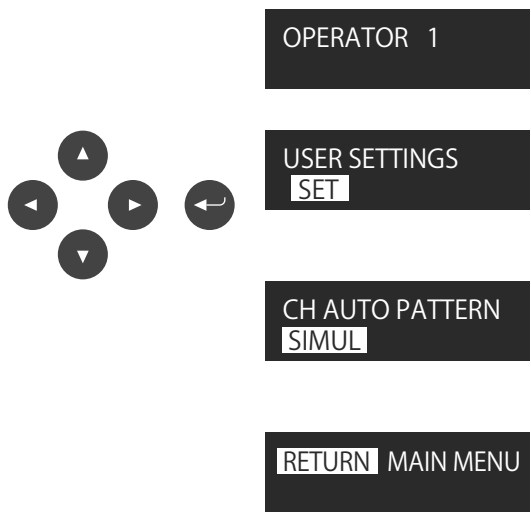

OPERATOR 1 Operator screen

USER SETTINGS
SET

① Display the user settings screen using the Up/Down keys and press the Enter key.

CH AUTO PATTERN
SIMUL

② Use the Up/Down keys to display the screen showing the item to be set. Make desired settings.
Example: Set CHAIR AUTO PATTERN

RETURN MAIN MENU

③ After completing the settings, display the RETURN MAIN MENU screen using the Up/Down keys and press the Enter key. The display returns to the operator screen.

■ Chair Auto Pattern

Three types of operation timing can be selected at the time of automatic operation.

- SIMUL (seat moves up and backrest goes back simultaneously)
Seat and backrest move simultaneously.
Although the operation time is shortened, the patient will experience more movement at the beginning.
- DELAY (automatically delayed)
Seat starts to move up → backrest starts to go back about 1 second later. Reduces initial movement experienced by patient (recommended)
- INDEP (automatic and independent)
Seat finishes moving up → backrest starts going down. The patient will experience less movement at the beginning, but the operation time will be longer.

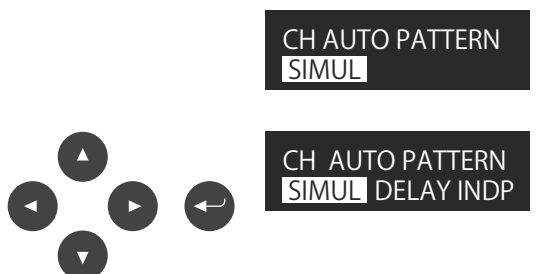

CH AUTO PATTERN
SIMUL

CH AUTO PATTERN
SIMUL DELAY INDP

Select the operation timing (SIMUL, DELAY, INDEP) using the Left/Right keys and press the Enter key to make the setting.

■ Linking the Operating Light to Chair Auto Operation

You can link automatic light switching to the chair automatic operations.

ON: Light comes on after chair AUTO 1, AUTO 2, or after movement to the gargle position is completed.
Also, the light goes off before reset operation starts.

OFF: Lighting is not linked to chair automatic operations

Linking to AUTO 1

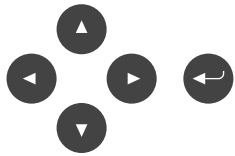

LIGHT AUTO1 LINK
ON

LIGHT AUTO1 LINK
OFF ON

Select ON/OFF using the Left/Right keys and press the Enter key to make the setting.

Linking to AUTO 2

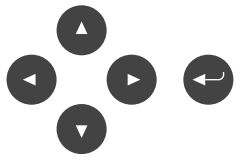

LIGHT AUTO2 LINK
ON

LIGHT AUTO2 LINK
OFF ON

Select ON/OFF using the Left/Right keys and press the Enter key to make the setting.

Linking to soft memory (movement to the gargle position)

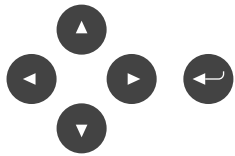

LIGHT AUTOS LINK
ON

LIGHT AUTOS LINK
OFF ON

Select ON/OFF using the Left/Right keys and press the Enter key to make the setting.

Linking to reset

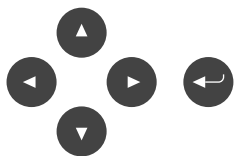

LIGHT AUTOR LINK
ON

LIGHT AUTOR LINK
OFF ON

Select ON/OFF using the Left/Right keys and press the Enter key to make the setting.

■ Linking Operating Light to Instruments

You can choose to link (ON) or to not link (OFF) automatic switching of the light to instrument pickup.

ON: When an instrument is picked up, the light comes on.

OFF: No link between picking up an instrument and operation of light.

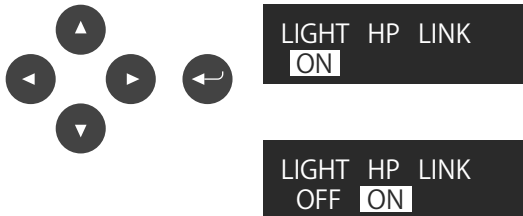

Select ON/OFF using the Left/Right keys and press the Enter key to make the setting.

■ Operating Light Brightness Adjustment Direction

You can select the brightness adjustment direction of the operating light.

BRIGHTEN: Gets brighter with each press.

DIM: Gets dimmer with each press.

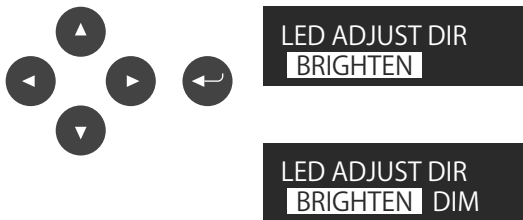

Select BRIGHTEN or DIM with the Left/Right keys and press the Enter key to make the setting.

■ Countdown timer completion sound

4 Types of completion sound for the countdown timer can be selected.

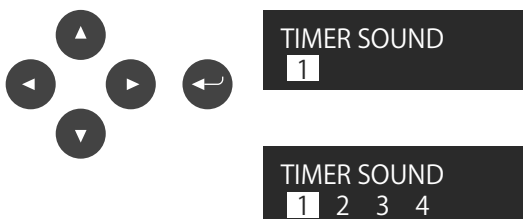

Use the Left/Right keys to select a TIMER SOUND from 1-4. When a digit is blinking, press the timer switch to hear the corresponding sound. Press it again to stop the sound.

Following selection, press the Enter key to confirm.



■ Buzzer volume

You can select the buzzer volume.

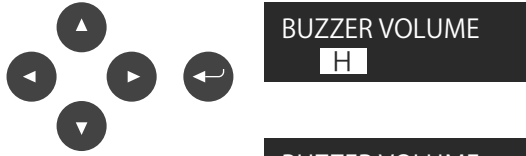

Use the Left/Right keys to select OFF or select one of 3 volume levels (L, M, H).

When the desired setting blinks, press the Enter key to confirm.



■ Scaler One-touch Mode Setting

Switches the ultrasonic scaler one-touch mode ON/OFF (for specification including a scaler).

ON: Stepping on the pedal starts continuous vibration. Stepping on the pedal again stops the vibration.

OFF: Scaler only vibrates while you are pressing on the pedal.

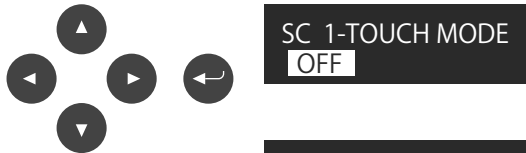

① Press the Up/Down keys to switch to the scaler one-touch mode display.

② Use the Left/Right keys to switch ON/OFF.

③ Press the Enter key to confirm.

■ Micromotor Speed Up/Speed Reduction Ratio Setting

When connecting a speed reduction attachment to the micromotor, set the attachment speed up ratio to display the rotation speed of the attachment.

- Speed up ratio 1:1.0-1:5.9 (change possible in 0.1 units)
- Speed reduction ratio 1.0:1-1024:1 (change possible in 0.1 units)

However, the number of rotations displayed is an “estimate” calculated using the speed up ratio set for the micromotor rotation speed, and may not match the actual speed of rotation. Use this after sufficiently checking the attachment specification etc.

Speed Up Ratio Setting

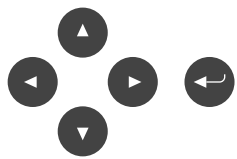

LS1 ATTCH RATIO1
SPEED UP 1 : 1.0

① Set the speed up ratio by pressing the Up/Down keys.

LS1 ATTCH RATIO1
SPEED UP 1 : 5.0

② After determining the speed up ratio, press the Enter key to confirm.

Speed Reduction Ratio Setting

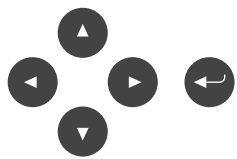

LS1 ATTCH RATIO2
SPEED REDC 1.0 : 1

① Set the speed reduction ratio using the Up/Down keys.

LS1 ATTCH RATIO2
SPEED REDC 4.0 : 1

② After determining the speed reduction ratio, press the Enter key to confirm.

■ Water Flow Timing (Variable Speed) Setting

When variable speed of the instrument is selected, the following 2 water injection timings can be selected. This can be set for each micromotor (LS) and air turbine (HS).

- INSTANT: Water flows as soon as you step on the foot control pedal
- DELAY: Water flow when you press the foot control pedal all the way down.

Settings for each circuit cannot be made if equipped with multiple circuits such as air turbine 2 circuit specifications and micromotor 2 circuit specifications etc.

Micromotor system (LS) Setting

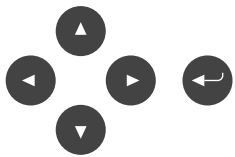

LS W TIMING VAR
DELAY

- ① Pressing the Up/Down keys displays the LS water flow timing setting screen

LS W TIMING VAR
INSTANT DELAY

- ② Set INSTANT or DELAY using the Left/Right keys and press the Enter key to confirm.

Air Turbine System (HS) Setting

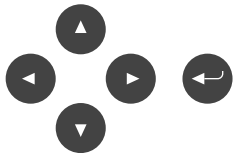

HS W TIMING VAR
INSTANT

- ① Press the Up/Down keys to display the HS water flow timing setting screen

HS W TIMING VAR
INSTANT DELAY

- ② Set INSTANT or DELAY using the Left/Right keys and press the Enter key to confirm.

■ Water Flow Timing (Constant Speed) Setting

When constant speed is selected for the instrument, the following 2 water injection timings can be selected. This can be set for each micromotor (LS) and air turbine (HS).

- INSTANT : Water flows as soon as you step on the foot control pedal
- DELAY : Water flow when you press the foot control pedal all the way down.

Settings for each circuit cannot be made if equipped with multiple circuits such as air turbine 2 circuit specifications and micromotor 2 circuit specifications etc.

Micromotor system (LS) Setting

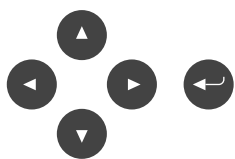

LS W TIMING CONS
DELAY

① Pressing the Up/Down keys displays the LS water flow timing setting screen

LS W TIMING CONS
INSTANT DELAY

② Set INSTANT or DELAY using the Left/Right keys and press the Enter key to confirm.

Air Turbine System (HS) Setting

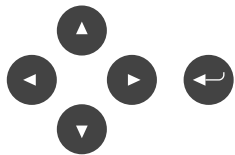

HS W TIMING CONS
DELAY

① Press the Up/Down keys to display the HS water flow timing setting screen

HS W TIMING CONS
INSTANT DELAY

② Set INSTANT or DELAY using the Left/Right keys and press the Enter key to confirm.

■ AI Catch Setting

AI catch ON/OFF, timing to catch the tube, and the timing delay period to release the tube can be set.

AI Catch ON/OFF Setting

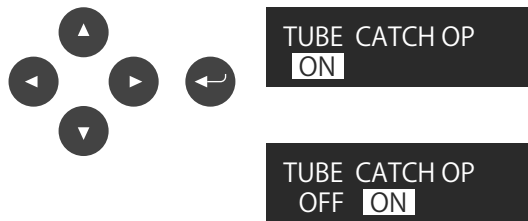

① Pressing the Up/Down keys displays the AI catch ON/OFF settings screen

② Set ON or OFF using the Left/Right keys and press the Enter key to confirm.

AI Catch/Timing Delay Period Setting



[factory setting: 0 seconds]

① Pressing the Up/Down keys displays the AI catch/timing (ON) settings screen

② Pressing the Left/Right keys reverses the display (blinks).

③ Set the delay period using the Up/Down keys. 0-9.9 seconds can be set.

AI Catch/Release Delay Period Setting



[factory setting: 3 seconds]

① Pressing the Up/Down keys displays the AI catch/release (OFF) settings screen

② Pressing the Left/Right keys reverses the display (blinks).

③ Set the delay period using the Up/Down keys. 0-9.9 seconds can be set.

■ Factory Reset Setting

Resets individual user settings to factory settings

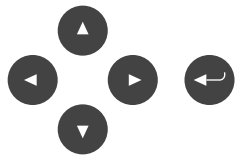

OPERATOR 1

① Display the operator No. to be initialized.

FACTORY RESET

② Pressing the Up/Down keys displays the factory reset screen.

FACTORY RESET
OFF **ON**

② ON/OFF can be selected when the Enter key is pressed.
Select ON using the Left/Right keys and press and hold the Enter key to reset the individual user settings to the factory settings.

■ RETURN MAIN MENU

The display returns to the operator screen.

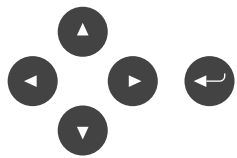

RETURN MAIN MENU

① Press the Up/Down keys to display the RETURN MAIN MENU screen.

OPERATOR 1

② Press the Enter key to return to the operator screen



5 Caring for the Unit

WARNING

| | |
|---|--|
|  | <p>Be sure to turn the main switch OFF when caring for/cleaning the main unit. Close the water supply valve and air supply valve as necessary.</p> <ul style="list-style-type: none">• Accidents and faults due to unforeseen circumstances/electric shock etc. may occur. |
| | <p>Be sure to wear rubber gloves when caring for/ cleaning the main unit to prevent infection.</p> <ul style="list-style-type: none">• An infection within the clinic may occur. |
| | <p>Sterilize and properly wipe successive parts such as each instrument that come into contact with the oral cavity.</p> <ul style="list-style-type: none">• If proper sterilization and wiping are not carried out suitable hygiene management is not employed, a nosocomial infection may occur. |
| | <p>When using equipment such as an autoclave, follow the operation instructions for each device. Use the following temperatures corresponding to the sterilization regulations.</p> <ul style="list-style-type: none">• Damage/faults both sterilized materials and equipment and an accident may occur. |
| | <p>The recommended autoclave sterilization conditions described in these operation instructions do not guarantee sterility. Always carry out sterilization validation by yourself.</p> <ul style="list-style-type: none">• An infection within the clinic may occur. |

5.1 Autoclave Sterilization

WARNING

| | |
|--|--|
|  | <p>Clean the equipment in a suitable manner before sterilization.</p> <ul style="list-style-type: none">• Insufficient sterilization may occur. |
| <h4> CAUTION</h4> | |
|  | <p>When autoclave sterilization is carried out, put items in a mesh basket, tray, sterilization pack etc. so that the sterilized material does not directly come into contact with the inner walls of the chamber. For models with high drying and standby temperature, remove the chamber promptly when sterilization is not being carried out.</p> <ul style="list-style-type: none">• The inner wall of the chamber and the drying process may reach a higher temperature than the set sterilization temperature and damage to the sterilized material may occur. |

5.1.1 Instrument Sterilization

⚠ CAUTION



If abnormalities such as deformation, degeneration, cracks etc. are found among sterilized sites, stop using the part and replace it with a new one. In particular, the resin products of the vacuum syringe and VS nozzle and SE flexible nozzle of the saliva ejector will be consumed faster than parts made of metal/silicone due to repeated sterilization.

- Continued use while there are abnormalities may cause problems such as accidents due to unforeseen damage.

Perform autoclave sterilization before and after treatment if necessary.

For details of the autoclave sterilization method, refer to the operation instructions of the relevant product.

Autoclave sterilization of the threeway syringe, vacuum syringe, and saliva ejector is carried out by removing the nozzle and tip from the main part. For the recommended conditions for autoclave sterilization refer to the following.

- Air turbine handpiece
- Micromotor attachment
- Micromotor motor cover
- How to remove the syringe case and nozzle of the threeway syringe (WS97,WS10-O-LD)

☞ pp. 57-60

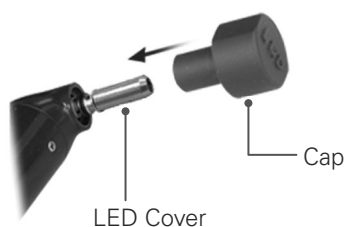

WS10-O-LD

Autoclaving can degrade the LED; put the cap on the LED cover before autoclaving.

- How to remove the syringe body, VS nozzle and VS tip of the vacuum syringe (VS110)
☞ pp. 118-119
- How to remove the ejector body and SE flexible nozzle the saliva ejector (SE110)
☞ pp. 120-121
- Ultrasonic scaler (handpiece, tip) Option

| Sterilized site | Sterilization temperature | Sterilization period |
|--|---------------------------|----------------------|
| Syringe case, nozzle of the threeway syringe (WS97) | 134±1 °C | 10 minutes or more |
| Syringe case, nozzle of the threeway syringe (WS10-O-LD) | 134±1 °C | 6 minutes or more |
| Syringe body, VS nozzle, VS tip of the vacuum syringe | 134±1 °C | 10 minutes or more |
| Ejector body of the saliva ejector, SE flexible nozzle | 134±1 °C | 10 minutes or more |

5.1.2 Holder Cup Sterilization

Perform autoclave sterilization before and after treatment if necessary.

■ Doctor-side holder

Before removing the holder cup, turn OFF the main switch of the dental treatment unit, and remove the instrument.

Holder Cup Removal

- ① Press **1** the release button of each holder cup on the under side of the tray and remove the holder cup from above **2**.

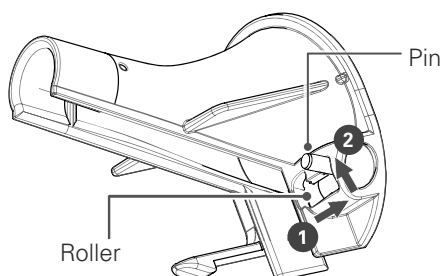
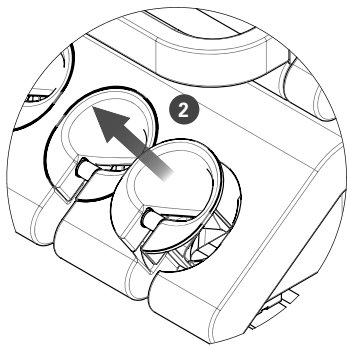
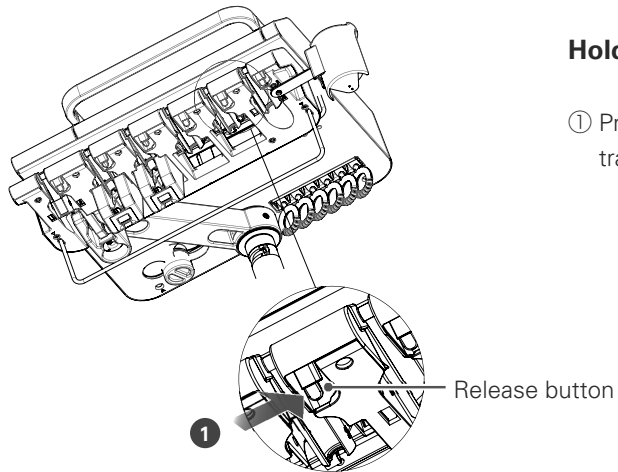

- ① Remove the instrument tube.
Move the pin at the back of the holder cup in the order shown in the drawing (**1** ⇒ **2**) and retract the roller. Pull the pin up until you hear a click.
Now remove the tube from the gap.

Autoclave sterilization

Recommended conditions 134±1°C, 5 minutes or more

Holder Cup Installation

- ① Pass the instrument tube through the lower gap then pass it through the holder cup.

The shape of the holder cup differs for each instrument.

Check that the holder cup/tube combination is correct using the marking on the side of the cup holder.

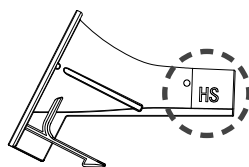
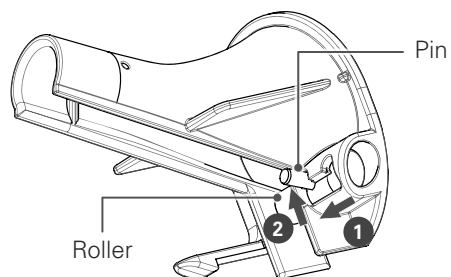

| Instrument | Seal |
|-----------------------------|-----------------|
| Threeway syringe | WS |
| Air turbine | HS |
| Micromotor | LS/SC |
| Ultrasonic scaler (Solfy) | (SOLFY) |
| Ultrasonic scaler (Newtron) | SC (NEWTRON) |

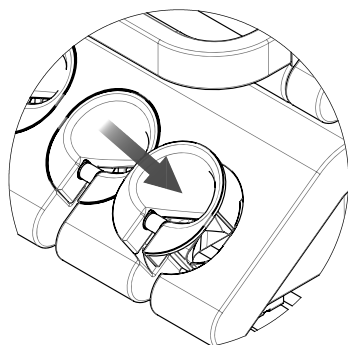

- ② Move the pin on the back of the holder cup in the order shown in the drawing (1 ⇒ 2) and remove the roller. Pull the pin up until you hear a click.

- ③ With the tube passed through the holder cup, attached the holder cup to the instrument holder.

Ensure that the holder cups are installed correctly in the original circuit order.

Push the holder cup in until you hear a click.

Assistant-side holder

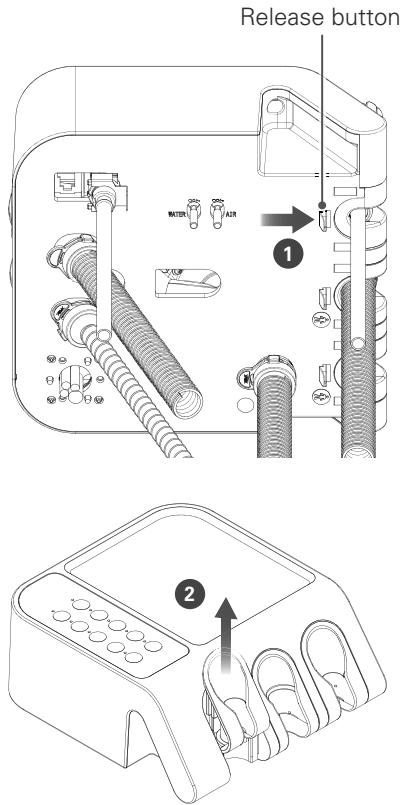

Before removing the holder cup, turn OFF the main switch of the dental treatment unit, and remove the instrument.

Holder Cup Removal

- Press (1) the release button of each holder cup on the under side of the tray and remove the holder cup from above (2).

Autoclave sterilization

Recommended conditions 134±1°C, 5 minutes or more

Holder Cup Installation

- The shape of the holder cup differs for each instrument.
Check that the holder cup/syringe combination is correct using the marking on the side of the holder cup.

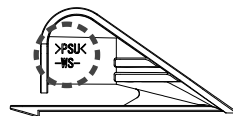
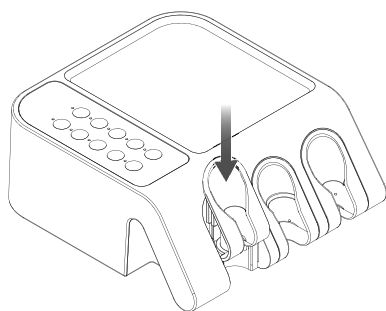

| Instrument | Seal |
|----------------------|-------|
| Threeway syringe | WS |
| Vacuum syringe VS110 | VS110 |
| Saliva ejector SE110 | SE |

- Fit the holder cup to the instrument holder.
Ensure that the holder cups are installed correctly in the original circuit order.
Push the holder cup in until you hear a click.

5.1.3 Other Sterilization

Perform autoclave sterilization before and after treatment if necessary.

■ Tray handle cover

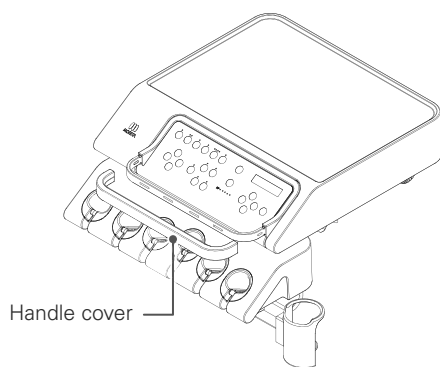

The silicone cover of the handle can be removed and sterilized using an autoclave.

When installing it, fit it to match the shape of the handle.

Autoclave sterilization Recommended conditions: $134\pm 1^{\circ}\text{C}$ 5 minutes or more

■ Operating Light Handle or Handle Cover

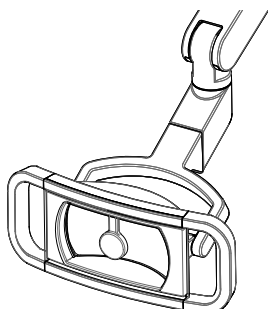

For details of the autoclave sterilization method, refer to the operation instructions of the relevant product.

■ Silicone Tray Sheet Option



Autoclave sterilization Recommended conditions: $134\pm 1^{\circ}\text{C}$ 5 minutes or more

■ Vial holder Option

Autoclave sterilization Recommended conditions: $134\pm 1^{\circ}\text{C}$ 5 minutes or more



5.2 Wiping with Disinfectant Ethanol

|  CAUTION | |
|---|--|
|  | <p>When cleaning with ethanol, always use disinfectant ethanol(76.9-81.4 vol%).</p> <ul style="list-style-type: none"> • Using other ethanols, solvents etc. may cause degeneration/deterioration/faults. |
|  | <p>When cleaning with ethanol, please avoid the areas where ethanol may ingress such as the gaps around joint/rotation axes/switches.</p> <p>Do not use excessive ethanol for other parts.</p> <ul style="list-style-type: none"> • Accidents due to a short circuit, degeneration, deterioration or damage may occur. <p>After cleaning with ethanol, do not place with other products (for example, do not put a mouse pad on the silicone tray sheet). Dry thoroughly and store separately.</p> <ul style="list-style-type: none"> • Color transfer from other products, deterioration may occur due to the effects of ethanol. |

5.2.1 Instrument Wiping

Wipe with disinfectant ethanol before and after treatment if necessary.

For details of the wiping method, refer to the operation instructions of the product.

- Air turbine handpiece
- Micromotor attachment
- Micromotor motor cover
- How to remove the syringe case and nozzle of the threeway syringe (WS97, WS10-O-LD)
 - ☞ pp. 57-60
- How to remove the syringe body, VS nozzle and VS tip of the vacuum syringe (VS110)
 - ☞ pp. 118-119
- How to remove the ejector body and SE flexible nozzle the saliva ejector (SE110)
 - ☞ pp. 120-121
- Ultrasonic scaler (handpiece, tip) Option

5.2.2 Wiping the Leather Seat

CAUTION

Do not subject the leather seat to the following conditions.

- ① Contact with clothing and bags containing dyestuffs such as real leather and denim
(risk of discoloration due to color transfer/degeneration)
 - ② Contact with vinyl/styrene/ABS/wood products/painted products
(risk of discoloration and degeneration/cracks)
 - ③ Contact with printed materials such as newspapers and magazines/printed pattern fabrics
(risk of color transfer and disfiguration)
 - ④ Contact and use of solvents/paints/chemicals/ adhesives/adhesive tapes etc.
(damage and deformation/discoloration/degeneration/hardening/softening)
 - ⑤ Use of bleach
(risk of discoloration and degeneration)
 - ⑥ Contact with or proximity to a heat source such as an iron or a stove
(damage and deformation/discoloration/degeneration)
 - ⑦ Partial loading due to being pressed against, scuffed, etc.
(damage and deformation/discoloration/degeneration)
- This may cause damage/degeneration/discoloration etc. of the leather seat or other parts.

- ① Wipe using a soft cloth or sponge containing a small amount of disinfectant ethanol, the supplied cleaning agent, a neutral detergent, or water
- ② Then, wipe with a dry cloth, taking care not to leave any residual moisture or detergent.

Please note that leather seats of certain colors are not compatible with disinfectant ethanol.

5.2.3 Wiping Other Parts

Wipe with disinfectant ethanol before and after treatment if necessary.

Wipe with a soft cloth such as gauze containing a small amount of disinfectant ethanol.

Wring out the cloth so it does not contain an excessive amount of disinfectant ethanol.

- Operating Light Handle or Handle Cover

- Operating Light Main Surface

- NOTE: For details of the wiping method, refer to the operation instructions for the product.

- Basin/catch

- Instrument main tube

- Disassembly of instrument holder (doctor side/assistant side)

- holder cup  pp. 100-102

- Silicone tray sheet

- Vial holder



- Doctor-side operation panel/assistant-side operation panel

- Flushing adapter

- Assistant-side armrest

- Doctor-side armrest Option

5.3 Other Cleaning Methods

|  CAUTION | |
|--|--|
|  | Do not dry heat (with dry sterilizer)/sterilize the various parts of the main unit. <ul style="list-style-type: none">• Discoloration/deterioration/faults may occur due to the high temperature. |
| | Do not soak, rinse, or boil any part of the main unit with a cleanser containing disinfectant ethanol or solvent (such as benzine or a thinner). <ul style="list-style-type: none">• Discoloration/deterioration/faults may occur. |

Other sterilization/ disinfection methods may have adverse effects on the main unit and parts.
Consult your reseller or the nearest MORITA CORP. subsidiary in advance.

5.4 Everyday Maintenance (before treatment)

| ⚠ CAUTION | |
|------------------|---|
| ! | <p>Once a day, before commencing treatment, drain residual water from the main unit using the following procedure.</p> <p>Take particular care after if the water has been there for a longer period, such as the day after a holiday.</p> <ul style="list-style-type: none"> • Since a certain amount of water remains in the warmer tank and tubes of the main unit and the quality of water will decrease if it is left for a long period, the remaining water should be discharged before use. |

Before commencing daily treatment, drain residual water from the main unit from each water line.

5.4.1 Flushing of Residual Water

■ Manual flushing

Water remaining in the water lines is flushed manually.

Carry out in the following procedures in the given order. If you do not follow this order, the flushing process will be less efficient.

“Flushing the cup water supply”



“Flushing the threeway syringe circuit”



“Flushing the air turbine handpiece circuit”



“Flushing the micromotor circuit”



“Flushing the ultrasonic scaler Option circuit”

The time required to flush each water line (refer to the table on the right) depends on the quantity of water within the main unit.

Besides the water in the main body of the unit, there may be water in the piping and so we recommend that you flush the circuits for longer than is specified in the table.

Estimated flushing times for each water line

| Water line | | Estimate |
|------------|-------------------|---------------------------|
| 1 | Cup water supply | At 1 minute or more |
| 2 | Threeway syringe | At 1 minute or more each |
| 3 | Air turbine | At 1 minute or more each |
| 4 | Micromotor | At 2 minutes or more each |
| 5 | Ultrasonic scaler | At 3 minutes or more |

Flushing the Cup Water Supply

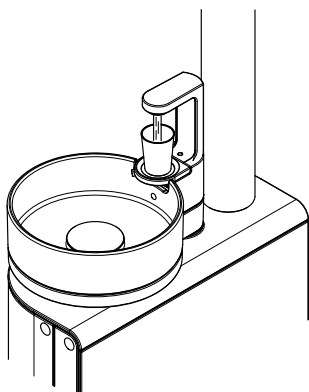

- ① Place a cup on the cup stand and supply Estiwater.
- ② When the supply of water has finished, discard the water in the cup and supply water again.
Repeat this 8 times or more.
- ③ Do the same for the water supply using the manual water supply switch.
In this case, supply water for 1 minute or more.

Threeway syringe circuit residual water drainage

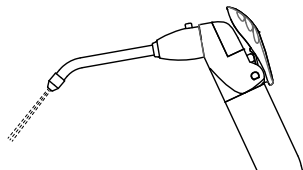

- ① Remove the threeway syringe from the instrument holder.
- ② Point the tip of the syringe toward the basin, push the W lever and flush for at least 1 minute.
- ③ Do this for the both doctor side and assistant side.
- ④ When finished, placed the threeway syringe in the instrument holder.

Flushing the air turbine circuit

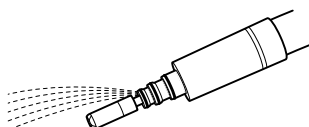

- ① Remove the handpiece from the instrument holder.
- ② Switch ON the water flow ON/OFF switch on the doctor-side operation panel.
- ③ Remove the air turbine from the tube.
- ④ Point the tip of the tube toward the basin, step on the foot control pedal, and flush for at least 1 minute.
- ⑤ On completion, connect the air turbine to the tube, and place it in the instrument holder.

If there is a second circuit (option), follow the same procedure.

Flushing the micromotor circuit

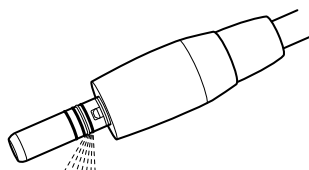

- ① Remove the micromotor from the instrument holder.
- ② Switch ON the water flow ON/OFF switch on the doctor-side operation panel.
- ③ Remove the straight handpiece and contra-angle handpiece from the micromotor.
- ④ Point the water supply port at the tip of the micromotor towards the basin, press the foot control pedal and flush for at least 2 minutes.
The water supply port is located beside the connecting tube. Check the position then flush.
- ⑤ When finished, place the motor in the instrument holder.

If there is a second circuit (option), follow the same procedure.

Flushing the ultrasonic scaler circuit

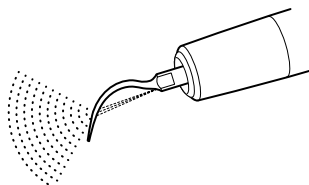

| ⚠ CAUTION | |
|------------------|---|
| ! | <p>When flushing, always be sure to attach the ultrasonic scaler main body to the tube with the tip attached.</p> <ul style="list-style-type: none"> • If vibration is started with the tip removed, an excessive load is applied to the circuit board and other parts of the device, and a fault may occur. |

- ① Remove the ultrasonic scaler from the instrument holder.
- ② Switch ON the water flow ON/OFF switch on the doctor-side operation panel.
- ③ Point the tip of the ultrasonic scaler toward the basin, step on the foot control pedal, and flush for at least 3 minutes.
- ④ When finished, remove the tip from the ultrasonic scaler and place the scaler in the instrument holder.

■ Flushing with the flushing device Option

Every day prior to commencing treatment, each water line needs to be flushed (residual water needs to be removed from piping).

1. Flushing preparation

Move the doctor-side tray closer to the basin side so that each tube reaches the flushing device.

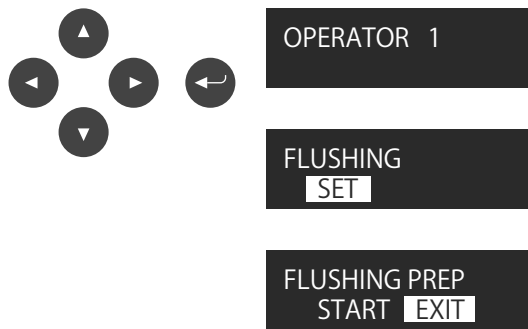

- ① Use the doctor-side operation panel.
From the operator No. display screen, switch to the flushing operation screen using the Up/Down keys.
- ② Press the Enter key.
- ③ The flushing preparation screen appears.

2. Flushing device/dummy cup set

Open the unit door and remove the flushing device adapter and dummy cup. Position the removed flushing device on the basin.

Hook the flushing device on the edge of the basin in the position shown below.

Also position the dummy cup on the automatic filler. Position it with the small port facing down.

NOTE: Depending on some specifications, the flushing device adapter may not be able to be stored in the unit

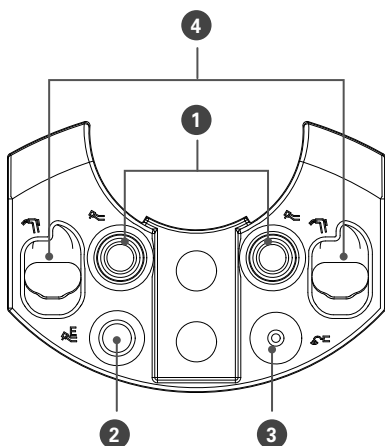
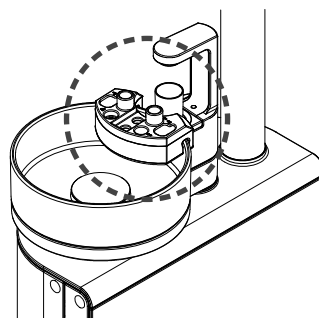
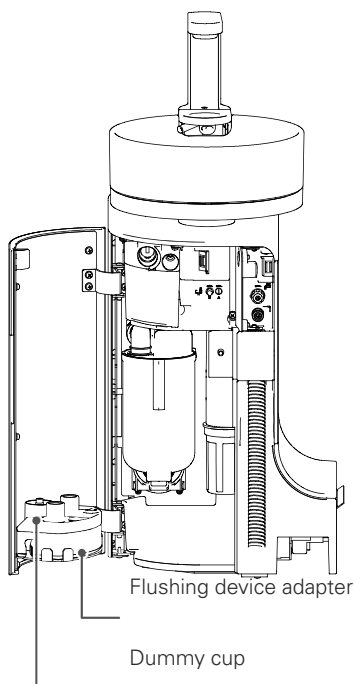

3. Setting Up Tubes





Set up the tubes in the flushing device

For how to remove of the instruments and attachments from the tubes, please refer to the table on the next page.

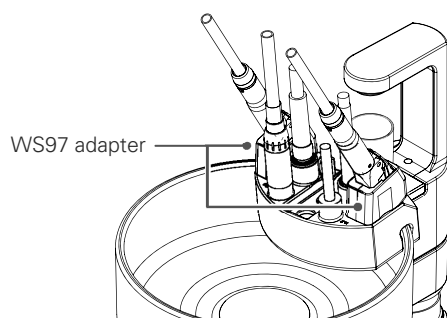
Thereafter, insert each tube into the corresponding hole in the flushing device adapter, taking care to keep the tub straight and insert it fully.

If the threeway syringe is WS97, attach the WS97 adapter to the flushing device adapter.



| Connection to the flushing device adapter | | |
|---|--|------------------------------|
| Display | Site | Preparation of tube |
| Tube for air turbine tube |  ① | Remove the air turbine |
| Tube for micromotor tube |  ② | Remove the attachment |
| Tube for ultrasonic scaler tube |  ③ | Remove the ultrasonic scaler |
| Tube for threeway syringe tube |  ④ | Remove the nozzle |

4. Flushing operation

FLUSHING PREP
START EXIT

Switch to START using the Left/Right keys and press the Enter key to start flushing.

FLUSHING CUP
150 sec CANCEL

Example: cup water supply

Any water remaining in the pipeline is automatically discharged in the following processes.

To stop part way through, press the Enter key to return to the flushing operation screen.

“Flush cup water supply” (about 150 seconds)



“Flush assistant-side threeway syringe circuit” (about 45 seconds)



“Flush doctor-side threeway syringe circuit” (about 110 seconds)



“Flush instrument circuit [5th circuit]” (about 40 seconds)



“Flush instrument circuit [4th circuit]” (about 30 seconds)



“Flush instrument circuit [3rd circuit]” (about 30 seconds)



“Flush instrument circuit [2nd circuit]” (about 30 seconds)



“Flush Instrument circuit [1st circuit] residual water drainage” (about 30 seconds)



Completion

FLUSHING ENDED
OK

NOTE: If there is a circuit with no setting, it is skipped.

NOTE: If there is a circuit with no setting, the flushing time may differ from the above.

NOTE: If you turn off the chair unit before starting and resume operation, the panel display will be the instrument's pickup display. To switch to the flushing start screen, press and hold the water injection switch.



5. Tube Removal

Remove each tube from the flushing device place it in the instrument holder as before.

Store the flushing device adapter and dummy cup inside the unit as before.

5.5 Everyday Maintenance (between patients)

5.5.1 Vacuum System Rinsing

■ Vacuum system rinsing

Flush the vacuum syringe and the saliva ejector piping with tap water.

If the inside of the vacuum tube becomes dirty, loss of suction power, failure, clogging etc. may occur.

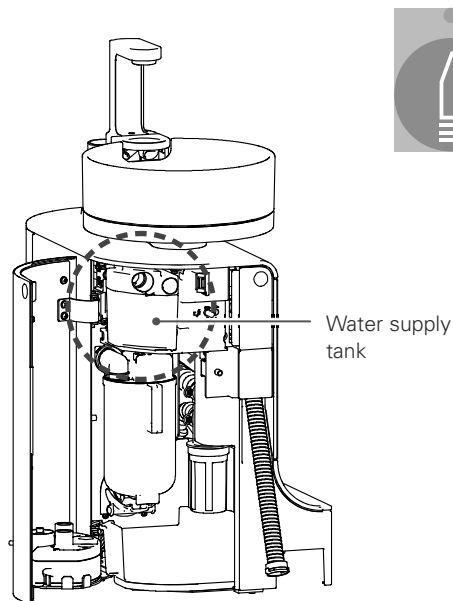
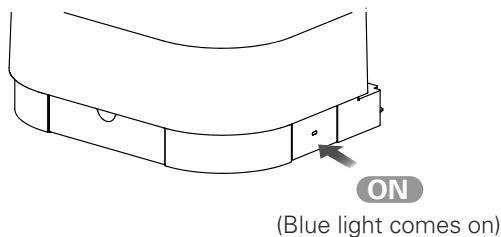

① Turn the main switch ON.

② Please confirm that you have chosen WATER for vacuum system cleaning in COMMON SETTING. If you have chosen CLEANSER for vacuum system cleaning, switch it to WATER please. [▶ p. 88](#)

③ Remove the VC nozzle and SE nozzle from the vacuum syringe and the saliva ejector.

And take them from holders. The vacuum system will work as soon as the vacuum syringe and the saliva ejector are taken from their holders. For stopping suction, press VACUUM SYRINGE SUCTION switch please. Open the unit door, and insert the vacuum syringe and the saliva ejector into the connection holes of the water supply tank. At this time, leave each adjustment lever fully open.

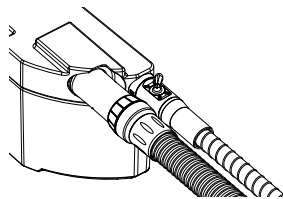

④ Press the vacuum system rinse switch on the assistant-side operation panel to start rinsing the piping.

⑤ When rinsing has finished, remove the vacuum syringe and saliva ejector from the water supply tank and put them back in their holders.

■ Rinsing the vacuum piping with cleanser

⚠ CAUTION



For the vacuum system cleanser, use "Mazak P" specified by MORITA.

Follow the instructions supplied with the cleanser.

- Failure to follow these instructions may lead to damage to the circuits or tubes, and damage, faults, water leaks or loss of suction may occur.

Rinse vacuum syringe and saliva ejector piping with cleanser.

If the inside of the vacuum tube becomes dirty, loss of suction power, failure, clogging etc. may occur.

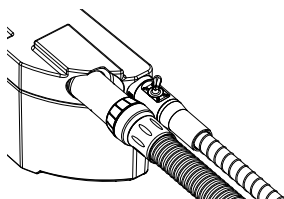
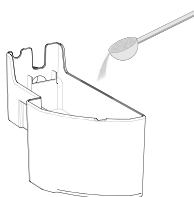
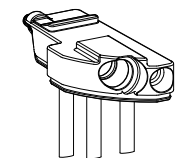
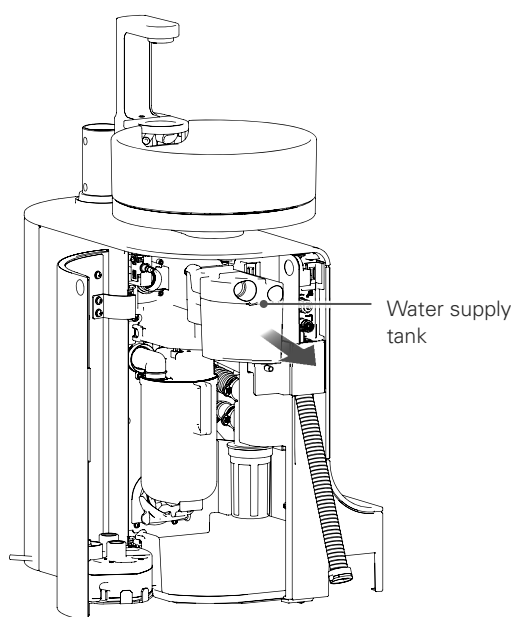

- ① Turn the main switch ON.
- ② Please confirm that you have chosen CLEANSER for vacuum system cleaning in COMMON SETTING. If you have chosen WATER for vacuum system cleaning, switch it to CLEANSER please. [p. 88](#)
- ③ Open the unit door, and remove the water supply tank.
- ④ Remove the water supply tank's lid and add 200 mL water or lukewarm water (approx. 40°C), to stir and dissolve them with a stirring stick. If too much water is added in at this point, the cleansing liquid or bubbles may overflow. When the stirring is finished, replace the water supply tank's lid as before.
If it is hard to fit the water supply tank into the unit, apply Vaseline on the O-rings of water supply tank.
Do not use a cleanser other than Mazak P as a malfunction may occur. Refer also to the operation instructions for Mazak P.
- ⑤ Remove the VC nozzle and SE nozzle from the vacuum syringe and the saliva ejector. And take them from their holders. The vacuum system will work as soon as the vacuum syringe and the saliva ejector are taken from their holders. For stopping suction, press VACUUM SYRINGE SUCTION switch please.
Insert the vacuum syringe and the saliva ejector into the connection holes of the water supply tank. At this time, leave each adjustment lever fully open.
- ⑥ Press the vacuum system rinse switch on the assistant-side operation panel to start rinsing the system piping. (At this time, about 100 mL of water will be automatically added)
- ⑦ When cleaning is finished, remove the vacuum syringe and saliva ejector from the water supply tank and return them to their instrument holders.

5.5.2 Automatic Rinsing of Vacuum Tank

Automatically rinse out the inside of the vacuum tank with air and running water.



- ① Press the vacuum tank automatic rinsing switch on the assistant-side operation panel.
- ② Rinsing starts automatically, continues for a certain period of time, then stops automatically.
To stop it part way through, press the switch again.

5.6 Everyday Maintenance (after use)

5.6.1 Cleaning the Vacuum Filter

⚠ CAUTION



When installing the vacuum filter, be sure it is fully inserted.

- If the vacuum filter is not fitted properly, the performance of the vacuum syringe/saliva ejector may be adversely effective, or a malfunction/clogging etc. may occur.

Every day after use, clean the vacuum filter on the assistant-side holder.

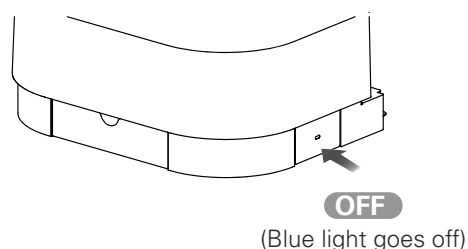

- ① Turn the main switch OFF.

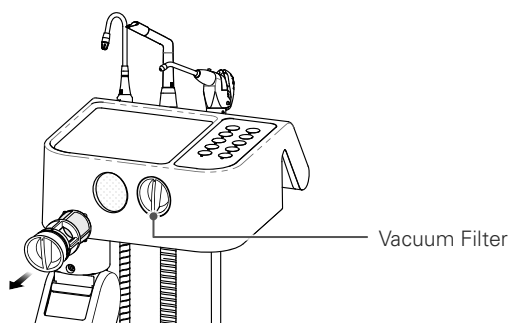

- ② Clean each vacuum pipeline and saliva ejector pipeline.
Remove the vacuum filter on the assistant-side holder side.
Grip the knob and pull it straight out.

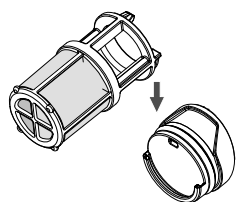

- ③ Slide the knob part of the vacuum filter in the direction of the arrow to disassemble.
After disassembling, rinse in running water.
The cut filter is a consumable part. There is a risk of injury if the net is torn or frayed, replace it with a new one.

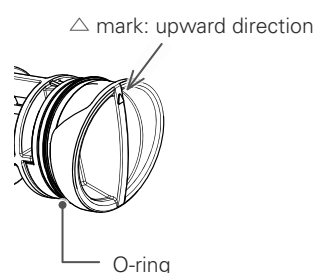

- ④ After rinsing, assemble as before.
After assembly, insert it back into the assistant-side holder.
With the △ mark on the front of the knob facing upward, push the filter in as far as it will go.
If insertion is difficult, apply Vaseline to the knob around the O-ring.

5.6.2 Cleaning the Basin

■ Cleaning the catch and filter

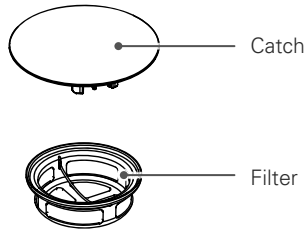

- ① Remove the catch and remove the filter from the waste water port.
 - ② Rinse the catch and filter under running water.
 - ③ Install the catch and filter as before.
- Press the filter firmly until it is fully inserted.

■ Basin Removal

The basin can be removed for cleaning. Refer to the following procedure.

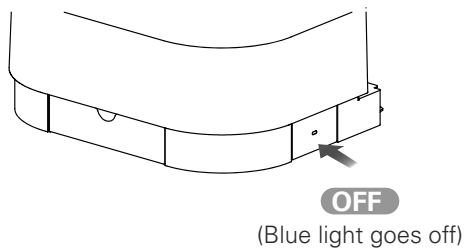

- ① Turn the main switch OFF.

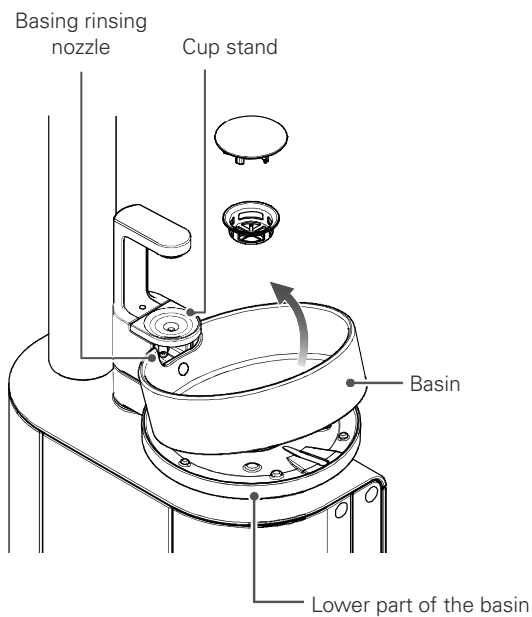

- ② Remove the catch and filter.
 - ③ Remove the basin.
- The basin fits into the packing of the basin lower part waste water port. Holding the lower part of the basin, lift the basin bowl upward. At this point, if you lift straight up, the basin bowl will make contact with the cup stand and basin rinsing nozzle. Be careful to avoid this when removing the basin bowl.

Note also that if you pull up on the basin bowl without pushing down on the lower part of the basin, there is a risk of a fault occurring in the swivel mechanism.

An anti-fouling coating has been applied to the underside of the basin bowl. Note that it will peel off if rubbed or scratched.

■ Cleaning the Basin

⚠ CAUTION



When cleaning the basin, do not use detergents containing abrasives, or hard cleaning materials such as a scourer/steel wool. Do not strongly rub it.

- Damage, scratching, and discoloration may occur.

Wipe off using a soft cloth impregnated a small amount of the supplied cleaning agent (or a neutral detergent), disinfectant ethanol, or water.

Then wipe dry with a dry cloth so that no moisture remains.

■ Basin Installation

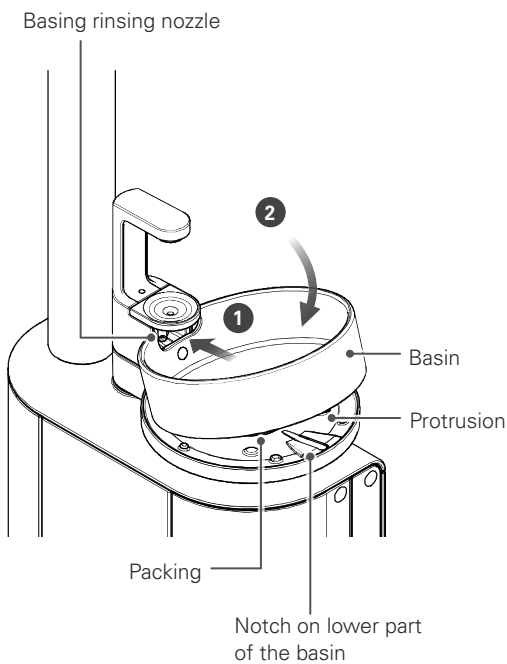

- ① Align the protrusion on the back of the basin with the notch on the base of the basin.

Insert the basin under the bowl wash nozzle (1) and then insert it into the packing of the lower part of the basin waste water port (2).

If the basin is not sufficiently pushed into the packing, there is a risk of water leakage so push the basin in until fully fitted.

If the basin is difficult to fit into the packing, apply Vaseline to the packing.

- ② Then attach the filter and catch as before.

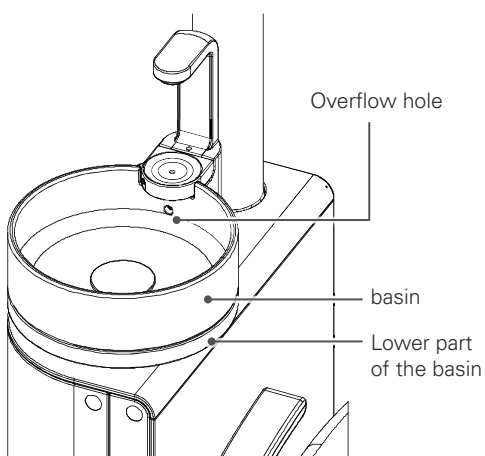

Caution

Do not flush a large amount of water over the overflow hole into the basin at once. If a large amount of water flows into the overflow hole, it may not be able to be exhausted and water may flow into the gap between the Basin and lower part of the basin. If water flows into the gap between the Basin and the lower part of the basin, wipe it off.

Note: The overflow hole is a hole for discharging the drainage to the outside so that the drainage does not enter the water supply pipe when the drain pipe is clogged.

5.6.3 Vacuum Syringe Disassembly and Cleaning

⚠ CAUTION



Do not use ultrasonic cleaning when disassembling and cleaning the adjustment lever. Do not scratch parts surfaces strongly with sharp instruments.

- The surfaces may be damaged and this may interfere with operation.

If the adjustment lever is stiff after performing a treatment, disassemble and clean the vacuum syringe.

■ Disassembly and Cleaning Method (VS110)

1. Disassembly

- ① Remove the vacuum syringe from the hose.
Loosen the cover nut on the hose and pull the vacuum syringe straight out.

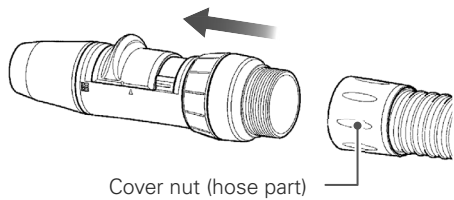

- ② Disassemble the tip fitting, drum case, and hose fitting.
To remove the tip fitting, hold the drum case then loosen the tip fitting by turning it in the direction of the arrow.
To remove the hose fitting, hold the hose fitting, turn the drum case lock nut in the direction of the arrow to loosen.

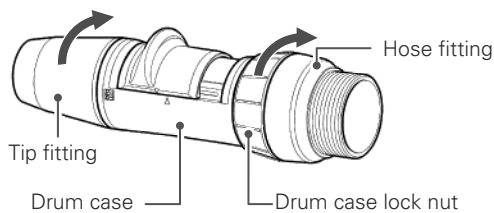

- ③ Take the drum receiver out of the drum case.
Pull the drum receiver straight out of the end of the drum case.
Note that the butterfly drum in the drum receiver cannot be disassembled.

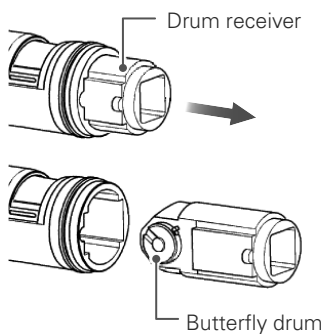

- ④ Disassemble the adjustment lever and drum case lock nut from the drum case.
Match the \triangle mark on the adjustment lever to the \triangle mark on the drum case and pull it upward to remove (1).
Then pull out the drum case lock nut in the direction of the arrow (2).
The drum case lock nut can not be removed with the adjustment lever fitted.

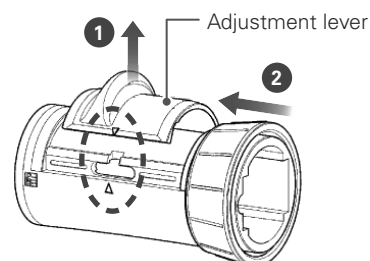

2. Rinsing the Parts

Rinse each disassembled part with running water.

Carefully remove hardened adhesions using a toothbrush etc.

After rinsing, apply a small amount of Vaseline to the drum receiver and O-rings in each part to make movement easy.

3. Assembly

After cleaning is finished, assemble the parts as before.

- ① Pass the drum case lock nut drum case lock nut over the drum case.
If the adjustment lever is fitted first, the drum case lock nut drum case lock nut can not be passed over the drum case.

- ② Fit the adjustment lever to the drum case.
The lever must be fitted with the correct orientation. Assemble as shown in the figure on the right.
Align the \triangle and \triangle marks and push it until you hear a click.

- ③ Position the drum receiver in the drum case.
Slide the adjustment lever in the tip direction (tip fitting direction) until it connects (1).
Align the stopper on the side of the butterfly drum to the position shown in the figure on the right (2).
Now, align the notch (3) on the drum receiver with the protrusion (4) on the drum case.

- ④ Insert the drum receiver into the drum case (5).

The pin on the inner side of the adjustment lever and the groove on the side of the butterfly drum engage, allowing the butterfly drum to rotate. Move the lever and check that the butterfly drum rotates.

- ⑤ Connect the tip fitting and hose fitting to the drum case.
After connecting, tighten the tip fitting and drum case lock nut in the direction of the arrow.

- ⑥ Connect the vacuum syringe and hose.
After connecting the vacuum syringe and hose, securely tighten the hose cover nut.

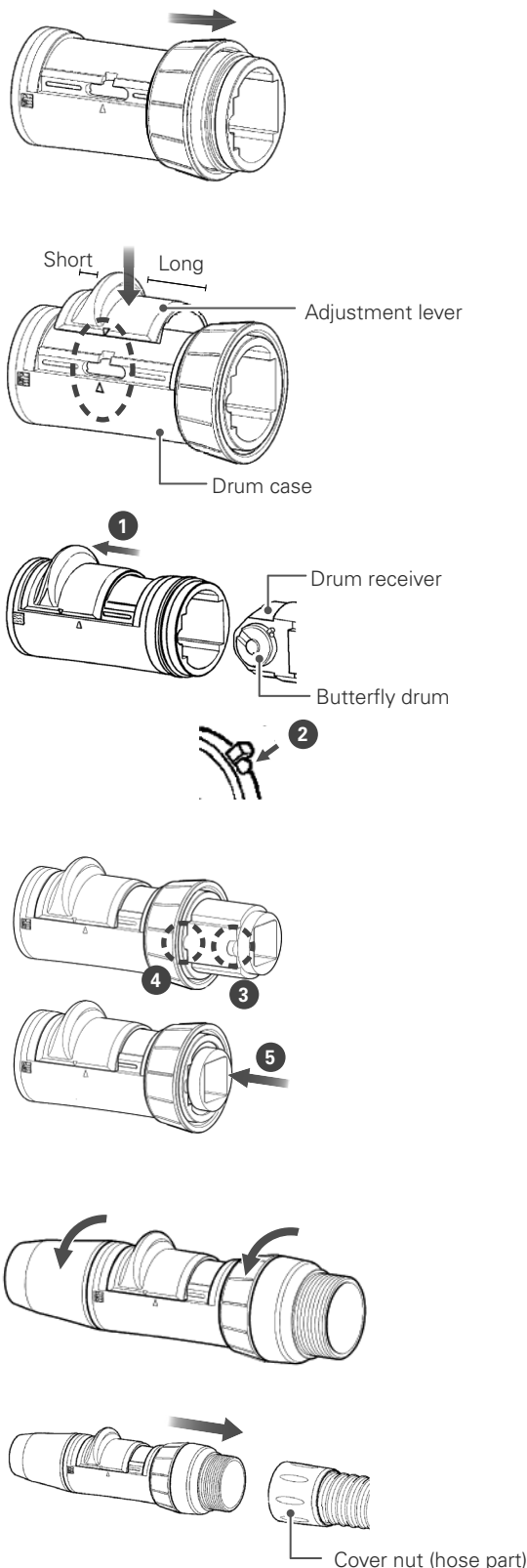

5.6.4 Disassembly and Cleaning the Saliva Ejector

If the adjustment lever is stiff after performing a treatment, disassemble and clean the saliva ejector.

■ Disassembly and Cleaning Method (SE110)

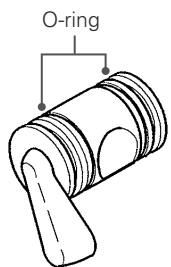
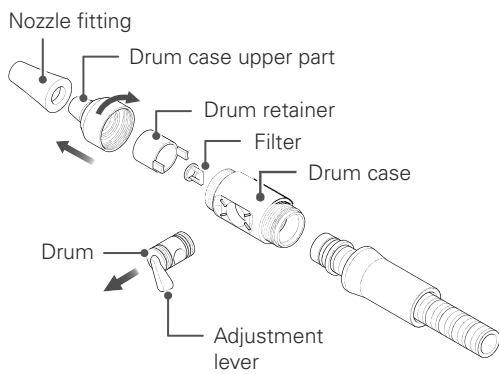
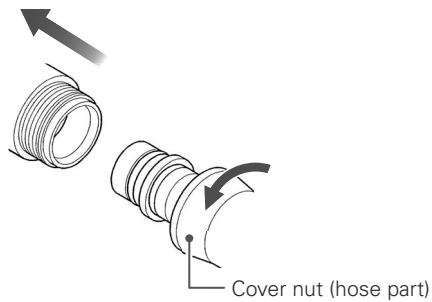

1. Disassembly

- ① Remove the ejector body from the hose.
Loosen the hose cover nut and pull off the syringe body in the direction of the arrow.
- ② Disassemble the ejector body.
Loosen the drum case upper part in the direction of the arrow and remove it.
- ③ Press the drum retainer and remove the filter.
- ④ Remove the drum from the drum case.
Push the flat surface on the opposite side of the drum lever and push it out.
Note that if you do not remove the drum retainer, the drum cannot be removed.
- ⑤ Pull the nozzle fitting off the drum case upper part.

2. Cleaning the Parts

Rinse each part of the disassembled saliva ejector with running water.

Carefully remove hardened adhesions using a toothbrush etc.
After rinsing, apply a small amount of Vaseline to the drum surface and O-rings in each part to make movement easy.

Check the condition of the O-rings at both ends of the drum. Replace them if they are deformed/hardened/missing etc.

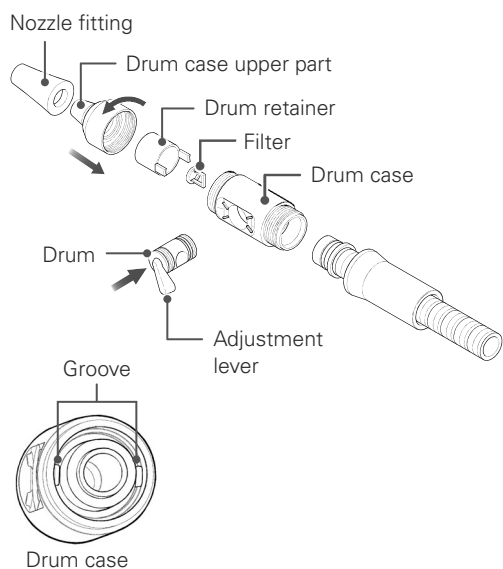

3. Assembly

After cleaning is finished, assemble the parts as before.

- ① Insert the drum in the drum case.
- ② Place the drum retainer in the drum case.
At this time, insert the drum retainer tabs into the grooves on the inside of the drum case.
- ③ Insert the filter in the drum case.
- ④ Install the drum case upper part on the drum case.
Tighten in the direction of the arrow to attach.
- ⑤ Fit the nozzle fitting to the drum case upper part.

After assembly, check whether the adjustment lever can be operated normally.

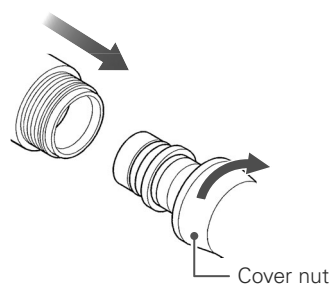

- ⑥ Connect the hose and the assembled ejector body.
After firmly inserting the tip of the hose into the ejector body, tighten the cover nut in the direction of the arrow.

5.7 Monthly Maintenance

5.7.1 Cleaning the Water Supply Tank

Clean the water supply tank inside the unit at least once a month.

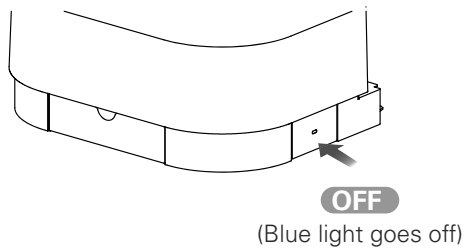

① Turn the main switch OFF.

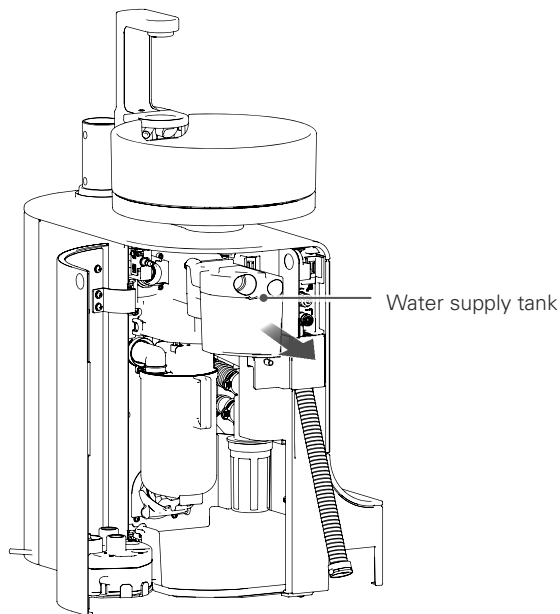

② Pull out and remove the water supply tank.

③ Disassemble the water supply tank and rinse out with running water.

④ Reassemble the water supply tank.

Fit the level surface of the suction pipe into the water supply tank lid.

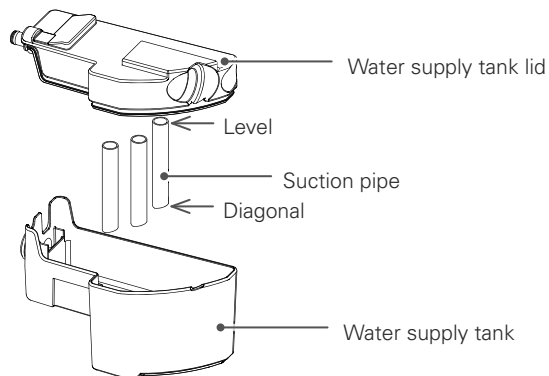

⑤ After cleaning, apply Vaseline on the O-rings of water supply tank, Install the water supply tank in the unit part as before.

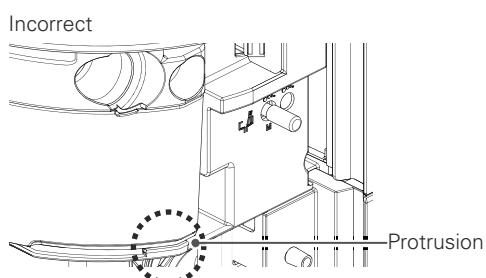
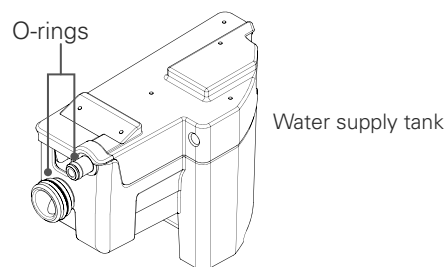
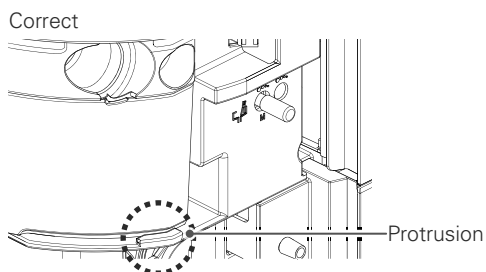

⑥ Push the Water supply tank into the unit as far as it will go. Attach to the back of the protrusion.(refer to the left figure)

5.7.2 Checking and Cleaning the Vacuum Tank

⚠ CAUTION



Clean the inside of the vacuum tank once or more every 6 months.

- Failure to do so may lead to a drop in performance, faults/pipe obstruction etc.

Securely install the vacuum tank.

- Inadequate installation may reduce the level of performance of the vacuum syringe/saliva ejector, or result in a leak/fault/clogging etc.

Check inside the vacuum tank at least once a month and clean as necessary.
Clean the inside of the vacuum tank at least once every 6 months.

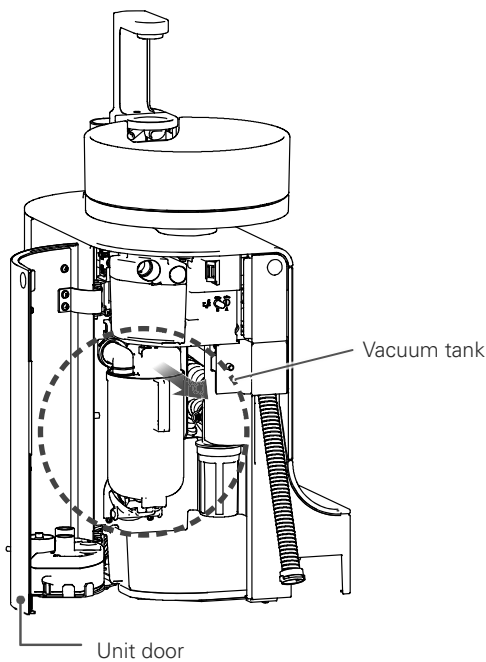

1. Removing the Vacuum Tank

- ① Turn the main switch OFF.
- ② Open the unit door.
Hold the handle of the vacuum tank and remove the tank by pulling it away from parts above.
As effluent may spill, spread a rag under the tank.

2. Removing the Tank Lid

Hold the vacuum tank firmly, turn the tank lid in the direction of the arrow, and pull up straight up to remove it.

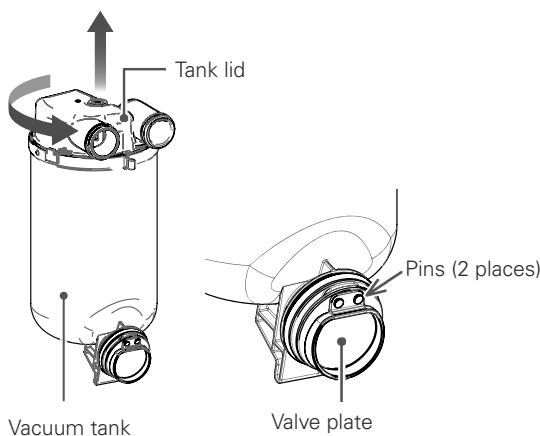

3. Cleaning the Vacuum Tank

- ① Rinse out the inside of the vacuum tank with running water.
- ② Remove the valve plate at the bottom of the vacuum tank and clean it.
Rinse the surface of the valve plate on the vacuum tank side.
When attaching the valve plate, position the flat surface to the vacuum tank side and fit the pins (2 places).

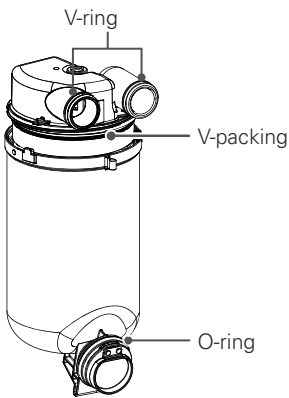

4. Installing the Tank Lid

① Apply Vaseline to the rings of the tank lid and vacuum tank.

② Align the matching marks (protrusions) on the top of the tank lid with the side of the vacuum tank (①), fit the tank lid straight, and rotate it in the direction of the arrow (②).

After rotation, make sure that the tank lid fittings and vacuum tank fitting face in the same direction.

Make sure that the tank lid is securely tightened.

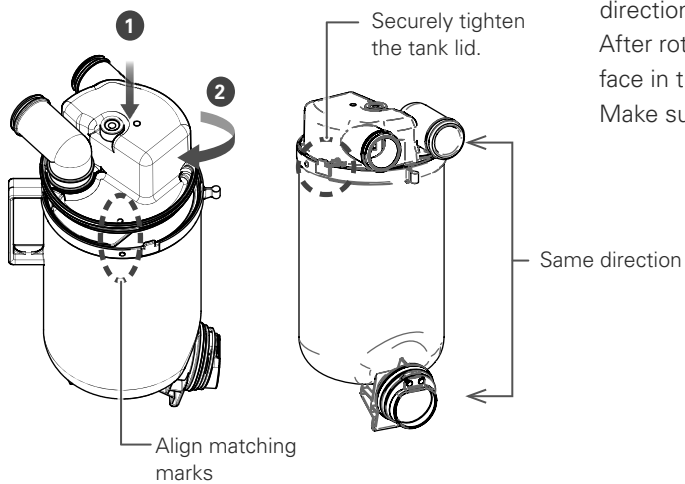

5. Installing the Vacuum Tank

Align the lower part of the vacuum tank with the underside of the mounting part on the unit (①) and push the upper part of the vacuum tank to fit it (②).

Make sure the vacuum tank is fitted securely.

When finished, close the unit door.

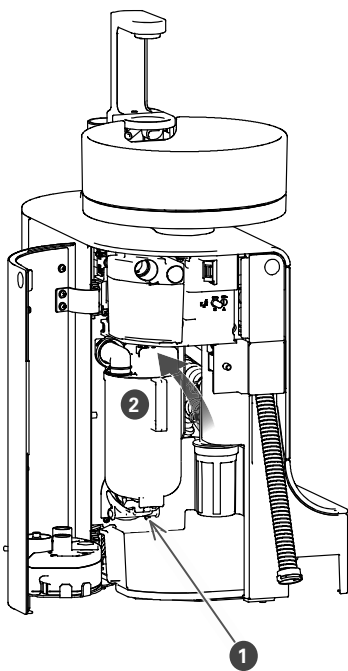

5.7.3 Amalgam separator

Option

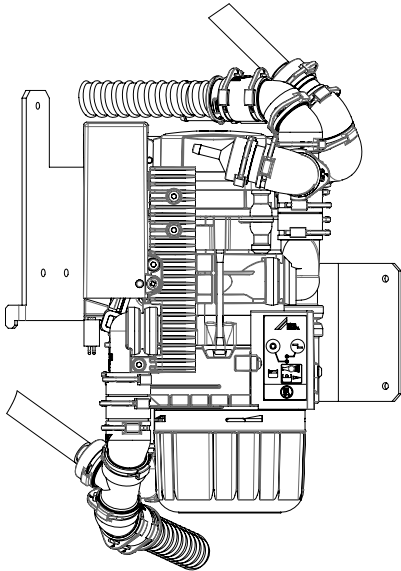

Please do not turn on the main switch with the cup set in the auto filler. The exchange sign of the amalgam separator may cause a false reaction. In this case, with the cup removed from the auto filler, please turn on the main switch again.

To prevent malfunction of the amalgam separator, water is not supplied for about 15 seconds after the main switch is turned on. During this time, auto filler and water injection will not come out, but it is not a malfunction.

5.7.4 Spittoon Valve

Option

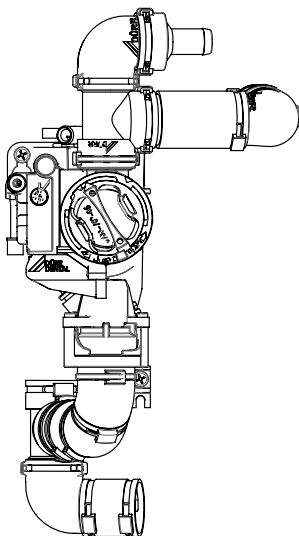

Please follow the directions in the manual.

5.7.5 Cleaning Inside the Drain Trap

⚠ CAUTION



- Clean the inside of the drain trap at least once a month.
- Failure to do so may lead to a drop in performance, faults/clogging etc.
- Be sure to install the drain trap filter and filter case.
- If not properly installed, a water leak/damage/fault may occur.

Clean the drain trap inside the unit at least once a month or if you notice that drainage from the basin is poor.

① Turn the main switch OFF.

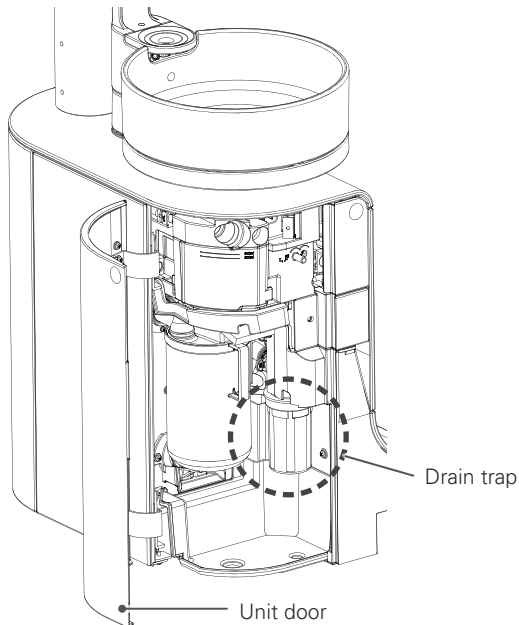

② Open the unit door and remove the filter case of the drain trap.

Turn in the direction of the arrow to loosen the filter case and release the lock.

Since effluent is collected in the filter case, be sure to pull it off in a downward direction and without tilting it.

Remove the filter case and trap filter assembly.

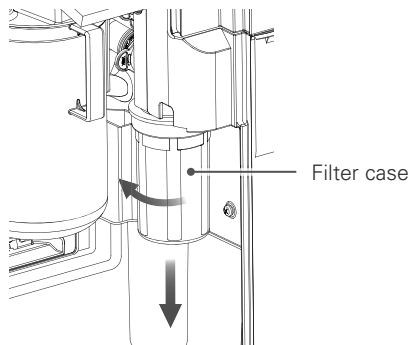

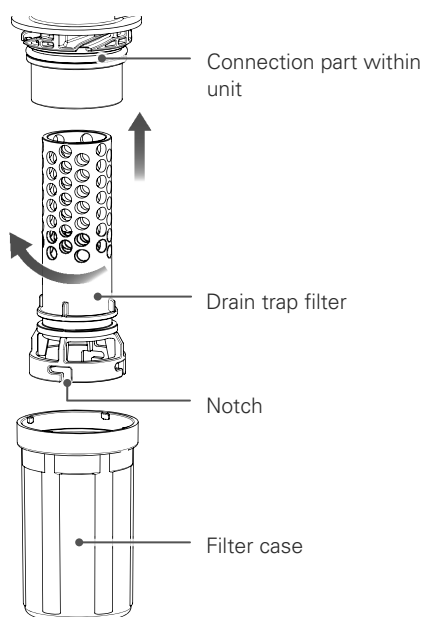

- ③ Discard the waste water inside the filter case.
- ④ Take apart the filter case and trap filter.
While holding the filter case, turn the trap filter as far as it will go in the direction of the arrow and then pull it upward.
- ⑤ Rinse the filter case and trap filter in running water.

- ⑥ When cleaning is finished, combine the filter case and the trap filter as before.
Align the protrusions within the filter case with the notches at the bottom end of the trap filter and insert. Next, rotate the filter case as far as it will go in the opposite direction to disassembly.

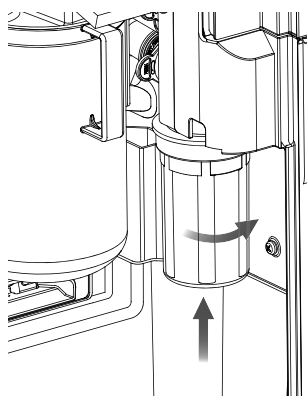

- ⑦ Attach the combined filter case and trap filter to the connection in the unit.
Press the assembled drain trap against the connection part and turn in the direction of the arrow to attach.
Check that the filter case is securely fixed.
Be sure to install the trap filter. Problems such as clogging of the waste water pipeline and poor drainage may occur.

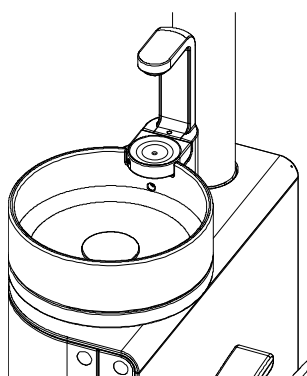

- ⑧ When installation is finished, close the unit door and allow about 2 cups of water to flow in the basin.
This fills the drain trap with water and prevents bad odors coming from the waste water pipe.
Check the surroundings of the drain trap for water leaks.

5.7.6 Cleaning the Oil Collector

⚠ CAUTION



Clean the inside of the oil collector at least once a month.
 • Failure to do so may cause overflow of oil from the oil collector or other faults.

At least once a month, discard the oil collected in the oil collector on the underside of the tray.
 Also check that the air turbine exhaust is normal.
 Even at less than a month, discard the oil if it is above the level line on the oil cup.

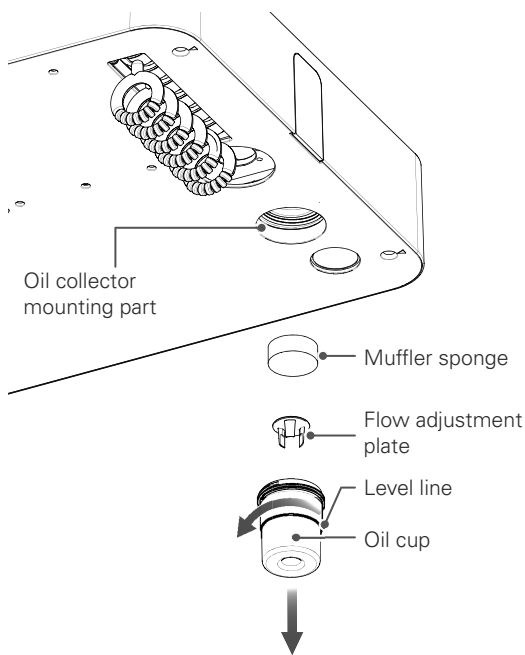





- ① Turn the oil cup in the direction of the arrow to remove it.
During removal, take care not to spill the collected oil.
- ② Soak up the oil in the oil cup using paper etc. and discard it.
- ③ Remove the flow adjustment plate located in the oil cup.
- ④ Pull out the muffler sponge fitted in the oil collector mounting part in the tray.
- ⑤ Rinse the oil cup, flow adjustment plate, and muffler sponge in running water.
After rinsing, remove all moisture from the surface.
- ⑥ Install by reversing the above procedure.
Fit the muffler sponge into the oil collector mounting on side of the tray.
With the flow adjustment plate fitted in place, screw in the oil cup.
- ⑦ After installing the oil collector, check the condition of the air turbine exhaust.
If exhaust air is not emitted, stop using the device, and consult a reseller or MORITA CORP. subsidiary.

If the O-ring at the tip of the air turbine tube is broken, water may accumulate in the oil collector over a short period of time.
 If this happens, replace the O-ring with a new one.

5.8 Annual Maintenance

5.8.1 Sterapore Cartridge Replacement

|  WARNING | |
|--|--|
|  | <p>Do not bring fingers close to the electrical parts inside the piping pit and do not expose parts to water. Do not operate the chair when the piping pit is open.</p> <ul style="list-style-type: none"> • Accidents such as an electric shock, short-circuit and pinching and damage/faults may occur. |
|  CAUTION | |
|  | <p>Be careful to avoid the following when handling sterapore cartridges.</p> <ol style="list-style-type: none"> ① Mixing up water and air cartridges ② Misconnecting IN and OUT ③ Disassembling cartridges ④ Reconnecting used cartridges ⑤ Using cartridges other than those normally connected to the mains water supply and or compressed air circuits ⑥ Using cartridges other than products designated by us <ul style="list-style-type: none"> • Not only will it be impossible to achieve the desired effects, but it may cause water leaks and air leaks and damage the unit. |
|  | <p>Before removing the sterapore cartridge, be sure to relieve the pressure within the circuit by following the procedure in these instructions.</p> <ul style="list-style-type: none"> • Forcibly removing it may lead to injury and other accidents. |
| | <p>Be sure to always close the water supply valve and air supply valve before starting replacement.</p> <ul style="list-style-type: none"> • Failure to do so may cause water/air leaks. |
| | <p>Be sure replace the sterapore cartridge every year.</p> <p>If a deterioration in performance is seen at less than one year due to water quality fluctuations etc., promptly replace the sterapore cartridge.</p> <ul style="list-style-type: none"> • Failure to replace the cartridge may cause water and air leaks due to a degradation in performance, pipeline clogging, pipeline foreign matter etc. or a fault. |
| | <p>Securely connect the sterapore cartridge.</p> <ul style="list-style-type: none"> • If the connection is incorrect or insufficient, a water leak/air leak/damage/fault may occur. |

Replace the sterapore cartridge once a year.

■ Removing the Pit Cover

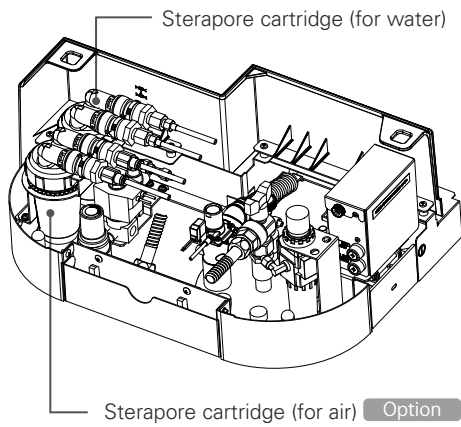
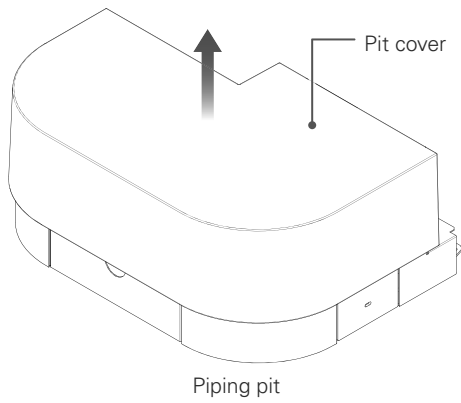
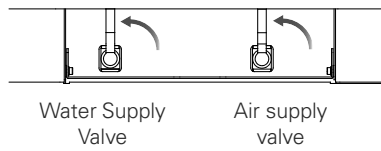

- ① Raise the chair to a position where the pit cover can be removed and turn the main switch OFF.
- ② Close the water supply valve and air supply valve by turning them in the direction of the arrow.
Expel water and air from the threeway syringe to relieve the internal pressure in the water and air circuits.
- ③ Lift off the pit cover of the piping pit.

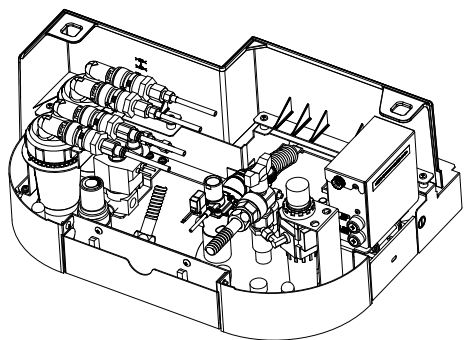

④ Position the sterapore cartridge in the pit as before.

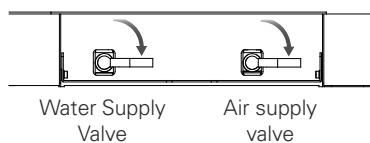

⑤ Turn the main switch ON.

⑥ Open the water supply valve and air supply valve by turning them in the direction of the arrows.

⑦ Expel water/air from the threeway syringe.

Check that water/air is being properly expelled and that there are no leaks around the one-touch joints.

⑧ Turn the main switch OFF and install the pit cover.

⑨ Turn the main switch ON again and check that there are nothing abnormal occurs in various operations.

When a sterapore cartridge for water is replaced, air is introduced into the water line. Operate the automatic filler, running the water until no more air is introduced.

5.9 Maintenance as Required

| ⚠ WARNING | |
|------------------|---|
| ! | <p>Do not leave moisture, detergent, ethanol etc on the main unit surface or inside the device.</p> <p>Do not allow moisture to adhere inside and do not do anything that could cause water to enter the unit such as directly wetting the panel switches and automatic filler.</p> <p>In the event that water does adhere, turn the main switch OFF, wipe thoroughly with a dry cloth etc. and dry thoroughly before reuse.</p> <ul style="list-style-type: none"> • Accidents such as fire due to a short circuit, discoloration/deterioration/malfunction/faults may occur. |
| ⚠ CAUTION | |
| ⊘ | <p>When cleaning each part of the main unit, do not use a cleaning agent other than the supplied cleaning agent (or neutral detergent).</p> <ul style="list-style-type: none"> • If you use chemical wipes, cleaning products impregnated with chemicals or items containing cleansers besides disinfectant ethanol (benzene, thinners etc.), it may adversely affect the unit, causing discoloration, degradation and faults. <p>Do not apply wax and solvents designed for use on floors to the housing/foot control etc.</p> <p>In the event that a product does adhere, wipe it off promptly.</p> <ul style="list-style-type: none"> • If the product is left it may cause discoloration/deterioration/faults. <p>When cleaning the main unit, do not spray water, cleaning agent etc. directly on the main switch.</p> <ul style="list-style-type: none"> • This may cause a fault. |
| ! | <p>If chemicals adhere to resin parts such as the instrument holders or tray surfaces, wipe them off immediately using a soft cloth with a little disinfectant ethanol.</p> <p>Do not allow ethanol to enter inside the main unit.</p> <ul style="list-style-type: none"> • Leaving chemicals adhering may cause discoloration or deterioration. |

5.9.1 Cleaning the Automatic Filler

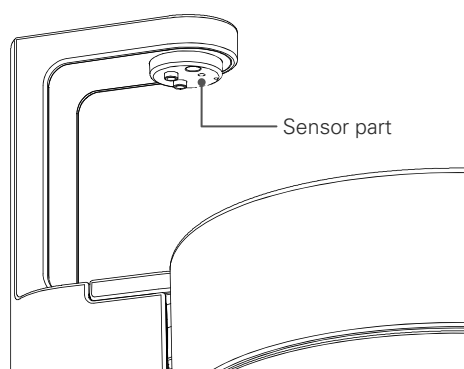



When cleaning the automatic filler, be careful not to allow foreign matter such as lint to enter into the notch in the sensor.
Ingress of foreign matter may cause a malfunction.

5.9.2 Cleaning Other Parts

- ① Add water, the supplied cleaning agent, neutral detergent, or disinfectant ethanol to a soft cloth, sponge etc. and wipe it off.
- ② Then, wipe with a dry cloth, taking care not to leave any residual moisture or detergent.

6 Maintenance and Inspection

|  WARNING | |
|--|--|
|  | Carry out maintenance and inspection in order to use this product safely and comfortably. • Failure to do so may cause a fault or unexpected accident. |
| | When reusing the unit after leaving it for a long period of time, always check that the main unit operates normally and safely before use. • Failure to do so may cause a fault or unexpected accident. |
| | If you think there is a fault, check this according to “7. Troubleshooting” in these operation instructions and consult the local reseller or MORITA CORP. subsidiary. • It is dangerous to disassemble, repair, or reconstruct this unit without permission. |
| | Regularly check and clean the circuit board (and earth) inside the chair to prevent dust from adhering. • Accidents such as fire, electric shock etc. may occur. |
|  | Do not perform maintenance checks on this product during patient treatment. • Accidents and faults due to unforeseen circumstances/electric shock etc. may occur. |

Since this product falls into the category of medical equipment requiring specialist maintenance and management, the medical facility should carry out maintenance and inspection (daily inspection and periodic maintenance inspection).

For instruments, operating lights, visible light irradiators etc., refer to the operation instructions and inspection list supplied with the product.

Parts list/technical data etc. for this product will be distributed at the request of repair companies. Contact your reseller or MORITA CORP. subsidiary.

6.1 Replacement of Consumable Parts

To maintain performance and ensure safety, replace consumable parts as set out in the following table.

When ordering and replacing consumable parts, contact your reseller or MORITA CORP. subsidiary. For the disposal methods of replaced parts, refer to “9. Medical Device Disposal” in these operation instructions.

When 10 years have elapsed after discontinuing production of this product, we may not be able to supply parts.

6.1.1 List of consumable parts

| List of consumable parts | | | |
|--------------------------|--|--|--|
| No. | Part name | Replacement timing | Replacement method |
| 1 | Various filters · Basin catch and filter · Drain trap filter · Filter of vacuum filter · Water supply filter | When damage, contamination, abrasions or stretching is observed; When the performance level drops | Consult with your reseller or the nearest MORITA CORP. subsidiary. |
| 2 | Sterapore cartridge · for water · for air | After 1 year of use; When the performance level drops | Refer to "5.8.1 Sterapore Cartridge Replacement" pp. 129-132 |
| 3 | Various O-rings, packing, diaphragms · O-ring for the drain trap · O-ring of vacuum filter · O-ring for the vacuum tank · O-ring for the vacuum syringe · O-ring for the saliva ejector · Valve plate for the vacuum tank waste water · Diaphragm for the control block | When damage, contamination, abrasions or stretching is observed; When the performance level drops | Consult with your reseller or the nearest MORITA CORP. subsidiary. |
| 4 | Various seats Seat, backrest and headrest's leather | When damage, contamination, abrasions is observed; When the performance level drops | Consult with your reseller or the nearest MORITA CORP. subsidiary. |
| 5 | Various main tubes | When damage, contamination, abrasions is observed; When the performance level drops | Consult with your reseller or the nearest MORITA CORP. subsidiary. |
| 6 | Various tubes for piping (Vacuum piping, etc.) | When damage, abrasions is observed; When the performance level drops | Consult with your reseller or the nearest MORITA CORP. subsidiary. |
| 7 | Various fuses | When it blows | Consult with your reseller or the nearest MORITA CORP. subsidiary. |
| 8 | Lights | When it blows | Consult with your reseller or the nearest MORITA CORP. subsidiary. |
| 9 | Covers · Headrest cover · Contour seat cover Option | When damage, contamination, abrasions or stretching is observed; When the performance level drops | Consult with your reseller or the nearest MORITA CORP. subsidiary. |
| 10 | Various silicone products · Tray handle · Vial holder · Water supply tank lid · Flushing device adapter · Silicone tray sheet Option | When damage, contamination, abrasions or stretching is observed; When the performance level drops | Consult with your reseller or the nearest MORITA CORP. subsidiary. |
| 11 | Parts for autoclave sterilization | When damage, contamination, abrasions is observed; When the performance level drops | Consult with your reseller or the nearest MORITA CORP. subsidiary. |
| 12 | Various disposable/paper products · Paper cups · Tops for paper cups · Tray paper | Every examination | Consult with your reseller or the nearest MORITA CORP. subsidiary. |

| List of consumable parts | | | |
|---------------------------------|---|--|--|
| No. | Part name | Replacement timing | Replacement method |
| 13 | Tube lifter | When damage, contamination, abrasions or stretching is observed; When the performance level drops | Consult with your reseller or the nearest MORITA CORP. subsidiary. |
| 14 | Instrument holder | When damage, contamination, abrasions or stretching is observed; When the performance level drops | Consult with your reseller or the nearest MORITA CORP. subsidiary. |
| 15 | Muffler sponge for the oil collector | When damage, contamination, abrasions or stretching is observed; When the performance level drops | Consult with your reseller or the nearest MORITA CORP. subsidiary. |
| 16 | Flexible tube for drainage/suction | When damage, contamination, abrasions or stretching is observed; When the performance level drops | Consult with your reseller or the nearest MORITA CORP. subsidiary. |
| 17 | Syringe case, nozzle of the threeway syringe | When damage/abrasion is seen; When the performance level drops | Consult with your reseller or the nearest MORITA CORP. subsidiary. |
| 18 | Various vacuum syringe nozzles, various tips | When damage/abrasion is seen; When the performance level drops | Consult with your reseller or the nearest MORITA CORP. subsidiary. |
| 19 | Various nozzles and tips of saliva ejector nozzle | When damage/abrasion is seen; When the performance level drops | Consult with your reseller or the nearest MORITA CORP. subsidiary. |
| 20 | Oil for hydraulic motors | When deterioration/evaporation occurs | Consult with your reseller or the nearest MORITA CORP. subsidiary. |
| 21 | MORITA multispray | When it runs out | Consult with your reseller or the nearest MORITA CORP. subsidiary. |
| 22 | Batteries | When exhausted | Replace with a new battery. |

6.1.2 Parts Replacement for Threeway Syringe

LED Replacement for light-equipped model

| ⚠ WARNING | |
|------------------|--|
| ! | Turn off the main switch before replacing the LED to avoid the risk of electric shocks or burns. |
| ⊘ | Do not shine the LED directly into the eye. This could impair one's eyesight. |
| ⚠ CAUTION | |
| ⊘ | Avoid getting burned by the LED or the LED cover, which can get quite hot. Wait for them to cool off before replacing the LED. |
| | Make sure the nozzle click into place securely; otherwise, air pressure could blow it off the syringe. |

- 1** Take the nozzle off the syringe and remove the LED cover by turning it in the direction indicated by the arrow in the illustration.



- 2** Take the LED out of its socket.



- 3** Line up the ridges and grooves and push the new LED straight into place.

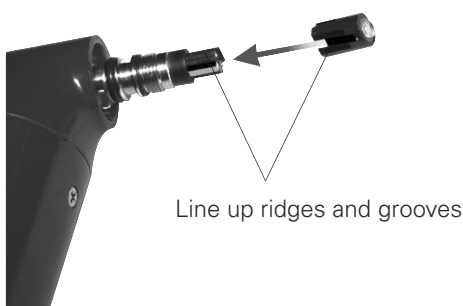

- 4** Replace the LED cover. Slide the nozzle in until it clicks into place. Connect the syringe to its tube and see if the light works properly.

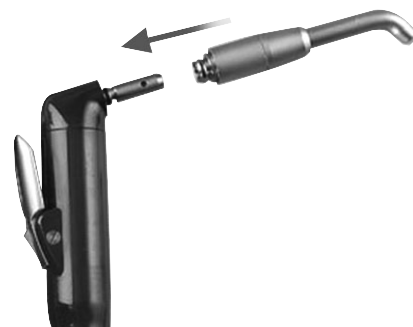

Water or air might leak if the LED cover is not tightened up properly.

6.2 Daily Inspection by the User

Inspect the device according to the table below and check that there are no abnormalities/ defects.

Carry out before use (startup inspection) and after use (shutdown inspection).

If an issue discovered at inspection is beyond the scope of the actions in the table or if any abnormality is found, consult your reseller or nearest MORITA CORP. subsidiary.

6.2.1 Startup Inspection

Check the contents of the table below before use.

| No. | Inspection item | Action | Reference page |
|-----|---|--|-------------------------------------|
| 1 | Is there rattling or looseness in the body/light/arm/unit/seat/instrument holder? | Adjust and tighten. | pp.10-13, pp.40-41, p.46, p.70 p.78 |
| 2 | Is there anything under the seat interfering with operation? | Make enough space around the seat and remove impediments, if any. | p.21 |
| 3 | Can the chair be stopped correctly? | Make sure that stopping (stop operation and operation of the various safety switches) can be performed normally. | p.21, p.31 |
| 4 | Are there any leaks in the water supply line/air/sterapore cartridge/drain trap/water supply device/main tubes (abnormalities such as leak marks, dripping noises)? | Check each part and correct connections. | p.9, p.73 p.126, p.131 |
| 5 | Are there any abnormalities such as rubbing, dislocation, tilting, noises etc. in the main unit housing (base housing/pit housing)? | With the chair raised, check visually that there are no abnormalities. | p.28 |
| 6 | Do the foot control, panel switch, and instruments (air turbine, motor, ultrasonic scaler, etc.) operate correctly? | Carry out trial operation to see if there are abnormalities in the switches/display/operation etc. Also check option specifications such as clean air system | pp.14-15 p.24, p.33 p.48, p.50 |
| 7 | Can the automatic filler/bowl washing/chair lock etc. be used properly? | Ensure that they can be used correctly and that the amount of adjustment/operation time is appropriate. | p.32, pp.76-77 |

6.2.2 Shutdown Inspection

Check after use.

| No. | Inspection item | Action | Reference page |
|-----|-------------------------|---------------------------|----------------|
| 1 | Is the main switch OFF? | Turn the main switch OFF. | p.18 |

6.3 Regular Maintenance Inspection

According to the Ordinance for Enforcement of the Medical Practitioners' Act and the notification from the Director of the Ministry of Health, Labor and Welfare, maintenance and inspection is designated, in principle, as work performed by medical institutions. Please carry out an inspection every 6 months in accordance with the regular maintenance and inspection list set out in the separately attached to the warranty card.

If any abnormality is found, please contact your reseller or MORITA CORP. subsidiary.

Note also that the inspection can be outsourced. For details, please contact your reseller or MORITA CORP. subsidiary.

6.3.1 Maintenance and Inspection by the User

Have the contractor check the items listed in the table below.

| No. | Content of inspection |
|-----|---|
| 1 | Movement of the seat and backrest (manual operation) |
| 2 | Movement of the seat and backrest (automatic operation) |
| 3 | Stop automatic operation and safety lock |
| 4 | Headrest operation |
| 5 | Mounting condition of seat and backrest |
| 6 | Automatic filler |
| 7 | One-touch connectors (water supply/air supply) |
| 8 | Sterapore cartridge |
| 9 | Air turbine handpiece connection |
| 10 | Operation of and air pressure supply to the air turbine handpiece |
| 11 | Air turbine hand piece circuit and water flow/lighting conditions |
| 12 | Micromotor connection and operation |
| 13 | Micromotor circuit and water flow/lighting conditions |
| 14 | Connection and operation of vacuum syringe and saliva ejector |
| 15 | Threeway syringe connection and operation |

6.3.2 Outsourcing Maintenance and Inspection to a Contractor

Have the contractor check the items listed in the table below.

| No. | Content of inspection |
|-----|---|
| 1 | Power supply voltage for device operation |
| 2 | Floor and fixing condition |
| 3 | State of electric circuit wiring |
| 4 | State of piping/tubes |
| 5 | Assembly condition of screws and exterior |
| 6 | Contamination within the unit |
| 7 | Condition of hydraulic circuits |
| 8 | Operating light power-supply voltage |

6.4 After-sales Service and Contact Information

If after-sales service is required, please contact your local dealer.

7 If Problems Arise

7.1 Items to be Checked before Requesting Repair

If problems occur during use, refer to the table below, check and take action.

If an improvement is not achieved even when the following checks are performed and actions are taken, or if any abnormality other than those in the description is found, please stop using the device and consult with your reseller or nearest MORITA CORP.

| Symptoms | Possible cause | Checks/actions | Reference page |
|--|---|---|-------------------|
| Even with the main switch ON, there is no power | The room breaker is OFF | Switch ON the circuit breaker on the interior distribution board. | — |
| | Fuse has blown | Request a fuse replacement. | p.143 |
| The seat and backrest do not move | A safety switch has been triggered | Remove impediments. | p.22 |
| | A temporary abnormality due to unforeseen circumstances such as electrical noise | Briefly turn the main switch OFF and turn it ON again. | pp.17-18 |
| The backrest moves when the foot pedal is stepped on | A safety switch has been triggered | Remove impediments. | p.22 |
| It cannot be operated | Chair lock is in operation | Release the chair lock switch. | p.32 |
| Nothing happens when the panel switch is pressed | Two or more switches have been pressed simultaneously | Be sure to press switches one at a time. | p.24 |
| | A specific switch stays in the pressed state | Check the condition of the switch panel. | p.24 |
| The micromotor does not work | Fuse has blown | Replace the motor fuse. | p.143 |
| Doctor-side instruments do not work | HP LOCK is in operation | Check the status of the HP LOCK and release the lock if necessary. | p.84 |
| The vacuum syringe/saliva ejector does not suck or suction is weak | The vacuum filter/vacuum tank are contaminated. | Clean them. | p.115, p.123 |
| | The vacuum filter/vacuum tank are improperly installed and there is a gap in the connection | Install it correctly. | p.115, p.123 |
| | Dirt in vacuum tank may cause a bad water flow or clog. At this time, the float switch in vacuum tank will work to stop suction. | Clean the vacuum tank. | pp.123-124 |
| | If you suck a large amount of water at one time while cleaning the vacuum tank, the float switch in vacuum tank will work to stop suction for the sudden rise of water level. | After exhausting all of water in the vacuum tank, restart vacuum suction again. | — |
| Basin does not drain properly | The basin filter/drain trap is dirty. | Clean them. | p.116, pp.126-127 |

7.2 Error Display

If the following error messages appear on the panel display during use, refer to the table below, check it and take action. If an improvement is not achieved even when the following checks are performed and actions are taken, or if any abnormality other than those in the description is found, please stop using the device and consult with your reseller or nearest MORITA CORP.

| Display | Possible cause | Checks/actions |
|-----------------------------------|--|--|
| SAFETY SW SEAT UP | The safety switch of assistant-side arm was activated when the chair moved up. (stand unit type only) | Check the condition of the assistant-side arm. |
| SAFETY SW SEAT DOWN | The safety switch was activated when the chair was lowered. | Check the condition of the assistant-side arm, backrest, foot support, and piping pit. |
| SAFETY SW BACKREST UP | The leg support underside safety switch was activated when the backrest was made upright. | Check the state of the underside of the leg support. |
| SAFETY SW BACKREST DOWN | The safety switch was activated when the backrest was tilted. | Check the state of the backrest. |
| SAFETY SW TRAY | The safety switch was activated when the auxiliary tray moves up. | Remove the load. |
| CHAIR ERROR 1 SERVO | The hydraulic servo motor is faulty. | Stop using and request inspection/repair. |
| CHAIR ERROR 2 CONTIN OP PROTEC | The protection circuit was triggered during continuous operation. | Stop using it and leave it for a while. |
| SAFETY LOCK SW BASIN | The chair moved when the basin moved to the patient's side. | Return the basin to the original position. |
| CHAIR LOCK 1 LOCK SW | The chair moved when the chair lock switch was pressed. | Release the chair lock switch. |
| CH COMM ERROR | Chair PCB control is faulty. | Stop using and request inspection/repair. |
| FOOT COMM ERROR | Foot PCB control is faulty. | Check the foot controller has fallen or tilted. If it does not return, request inspection/ repair. |
| SERVO ERROR 1 | HS variable speed mechanism fault. | Stop using and request inspection/repair. |
| SERVO ERROR 2 | HS variable speed mechanism fault. | Stop using and request inspection/repair. |
| VR ERROR | A potentiometer in the foot control is faulty. | Stop using and request inspection/repair. |
| ERR LS OVERHEAT | The protection circuit was triggered during the micromotor operation. | Stop using it and leave it for a while. |

7.3 Fuse

| | |
|------------------|--|
| ⚠ WARNING | |
| ! | When replacing the fuse, always turn the main switch OFF. • Failure to do so may result in an accident such as an electric shock or a fault. |
| | If a fuse blows, there may be a problem with the electric wiring, so promptly consult your reseller or nearest MORITA CORP. subsidiary for an inspection. • If the unit continues to be used as is, an accident caused by electric leakage etc. or failure may occur. |
| ⚠ CAUTION | |
| ! | When replacing the fuse, be sure to use a fuse of the same rating, same characteristics, and same type as the IEC standard. |
| | • Using a substitute items (such as wire) could result in a fire due to overheating of the electric wires. |

Fuse replacement should be performed by a technical service representative.
Ask your reseller or nearest MORITA CORP. subsidiary.

■ When use is interrupted, after completion of treatment

When the fuse blows, replace it with a new one using the following procedure.
Use a medium Phillips screwdriver.

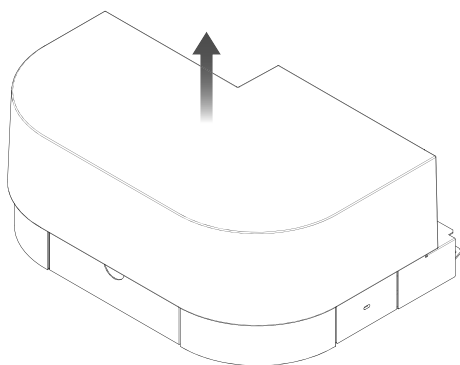

- ① Make the chair go up.
- ② Turn the main switch OFF, Lift the pit cover up and remove it.
- ③ Replace the fuse in the fuse holder.
Remove the cap of the fuse holder (15A uses a medium-sized Phillips screwdriver), extract the blown fuse, and replace it with a new one.
Be sure not to confuse the rating, characteristics, and model of fuse.
- ④ Installation is completed by installing each part in reverse order.

If the fuse blows again, the electric wiring may be abnormal.
At this time, stop using the device, turn the main switch OFF and ask your reseller or the nearest MORITA CORP. subsidiary for an inspection.

*1: conditions vary depending on specifications. Follow the main unit notes.

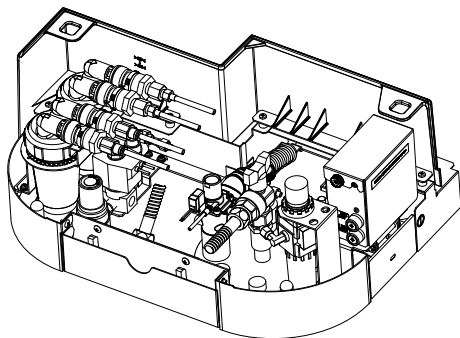

8 Warranty and Repair

8.1 Warranty of this Product

In the event of a malfunction following correct use in accordance with the operation instructions, the product will be repaired or replaced free of charge within the warranty period based on the conditions and scope described in the separate Warranty Card.

Read the "Content of Warranty" on the back of the Warranty Card for details.

8.2 Warranty Card

When purchasing this unit, fill out the prescribed details on the separate Warranty Card, give it to the reseller, and keep the warranty in a safe place.

8.3 Repair

8.3.1 Before Requesting a Repair

Please check the symptoms/condition according to "7.Troubleshooting" in these operation instructions before requesting a repair.

8.3.2 Requesting a Repair

■ Repair request within the warranty period

Attach the Warranty Card, and send the request to your reseller or nearest MORITA CORP. subsidiary. We will respond free of charge.

You will bear the actual cost of parts not covered by the warranty such as consumable parts.

■ Repair request outside the warranty period

Consult your reseller or nearest MORITA CORP. subsidiary. If the performance can be maintained/restored by repair/parts exchange, we will apply a charge.

8.3.3 Spare Part Maintenance Period

The manufacturer's stores spare parts for a period 10 years after discontinuation of the product. It may not be possible to respond to repair requests/parts orders after this period has elapsed.

9 Disposal of the Medical Device

9.1 Disposal of This Product

This product and accompanying parts/consumable parts fall into the category of medical devices. Please observe the disposal regulations in the applicable area.

Check with a dentist or physician that the infectious waste from the medical device is in a non-infectious state and ensure that the medical institution consigns industrial waste material and industrial waste subject to special control to a processing company qualified to deal with it.

Follow regional provisions for waste material and packaging materials that are not regarded as infectious waste.

Prior to disposal of the cordless foot control, remove the batteries from the foot control.

10 General Information













10.1 Specifications

| | | |
|--|--|----------------------------------|
| Name | signo T500 | |
| Non-proprietary name | Dental Treatment Unit | |
| Manufacture and marketing | J. MORITA TOKYO MFG. CORP. J. MORITA MFG. CORP. (WS10-O-LD) | |
| Model | TUA60 (chair mount type) / TUA70 (stand unit type) | |
| Intended purpose | This product, installed in a dental clinic, locates a patient to a position for medical examination, delivers air, water, vacuum, and electricity to dental equipment which is intended to be attached and operates it, and supplies and drains water for rinsing out patient's mouth. | |
| Power-supply voltage | 220/230/240V AC | |
| Power supply input | 1kVA | |
| Frequency | 50/60Hz | |
| Input pressure | 0.39-0.78MPa (air) 0.20-0.59MPa (water) | |
| Vibration mode | Longest 50 seconds ON/ shortest 5 minutes OFF (hydraulic motor) | |
| Protect against electrical shock | Class I Equipment Permanently installed devices Type B applied part. * However, connected devices follow the classification of each device. | |
| Applied parts | Type B(micromoter,air turbine) Type BF(ultrasonic scaler) | |
| Protection from harmful ingress of water or ingress of solids. | IPX1 (foot control) | |
| Seat type | contour type/foot support type | |
| Seat pad height (from the floor) | Lowest position 400mm±10mm Highest position 800mm±10mm | |
| Backrest angle (relative to the horizontal) | Most upright 78±2° Most tilted 2±2° | |
| Weight | TUA60: about 260kg/TUA70: about 280kg | |
| Maximum loading mass | 150kg (Seat: 89kg, Backrest: 61g) | |
| Seat lifting system | Hydraulic electrical vertical lift | |
| Threeway syringe water jet/spray amount | 30mL/15sec or more (WS97) 60mL/15sec or more (WS10-O-LD) | |
| Vacuum syringe suction volume | 140 L/min or more (Suction motor performance: equivalent to 15 kPa at low suction 0.17 m ³ / min ~ equivalent to 17.64 kPa at high suction 0.6 m ³ / min) ^{Note 1} | |
| Vacuum syringe vacuum | -8.0 kPa (static pressure) (suction motor performance: flow 900 L/min, suction pressure 14.0 kPa) ^{Note 1} | |
| Maximum load power | Warmer tank: 190 W threeway syringe: 20 W | |
| Maximum permitted load | Foot control pedal: 1350 N | |
| EMC specifications | Conforms to IEC 60601-1-2:2014 | |
| Cordless foot control | Frequency band | ISM 2.4 GHz |
| | Radiation ability | 4.5 dBm e.i.r.p (Max 2.8mW) |
| | Supply | Primary battery |
| | Battery type / quantity | AA alkaline batteries / 3 pieces |

[Please note that specifications and appearance may change without prior notice for product improvement purposes.]

Note 1: Low suction: equivalent to EV- 12- II of J MORITA CORP / high suction: equivalent to TCS- 1.5 MAX of TOKYO GIKEN,INC.



10.2 Symbols

| | | | |
|---|---|---|---|
|  | Conforms with the European Directive, 93/42/EEC. | IP X 1 | IP code Liquid ingress protection; Level 1 |
|  | Conforms with the European Directive, 2011/65/EU. |  | Alternating current |
|  | Manufacturer |  | Type B applied part |
|  | Date of manufacture |  | Type BF applied part |
|  | Authorized representative in the European Community |  | ON/OFF (push-push) |
|  | Serial number |  | Refer to instruction manual/booklet |
|  | Conforms with the WEEE Directive | | |

10.3 EMC Electromagnetic Compatibility EMC

TUA60/TUA70 conforms to electromagnetic compatibility in IEC 60601-1-2:2014.

The following sentences are "Guidelines and a Declaration of Manufacturers and Distributors" required as attached document according to IEC 60601-1-2:2014 on electromagnetic compatibility.

|  WARNING | |
|--|---|
|  | This product requires precautions related to EMC and it is necessary to install and use the product according to the EMC information described in these operation instructions. |
| | Portable and mobile RF communication equipment may affect this product. |
| | Portable RF communications equipment should be used no closer than 30cm(12 inches) to any part of the TUA60 /TUA70, otherwise, degradation of the performance this equipment could result. |
| | If accessories other than those sold as replacement parts by the marketing authorization holder are used, performance of this product may deteriorate regarding EMC. |
|  | The use of accessories and cables other than those specified, with the exception of replacement parts sold by J. MORITA TOKYO MFG CORP. may result in increased emissions or decreased immunity of the TUA60 /TUA70. |
| | Where possible this product should not be placed adjacent to other equipment, and should not be use with other equipment. If use with other equipment is required, only proceed after observing that the unit and other equipment work properly together. |

| EMISSION | | |
|--|--------------------|--|
| Emissions Test | Compliance | environment |
| RF emission CISPR 11 | Group 1 Class B | Professional healthcare facility environment |
| Harmonic distortion IEC61000-3-2 | Class A | Professional healthcare facility environment |
| Voltage fluctuation and Flicker IEC 61000-3-3 | Complies | Professional healthcare facility environment |

| IMMUNITY | | | |
|--|--|---|--|
| Phenomenon | Basic EMC standard or test method | IMMUNITY TEST LEVELS | Environment |
| Electrostatic Discharge (ESD) | IEC 61000-4-2 | ±8 kV contact ±2, ±4, ±8, ±15kV air | Professional healthcare facility environment |
| Radiated RF EM fields | IEC 61000-4-3 | 3 V/m 80 MHz-2.7 GHz 80% AM at 1kHz | Professional healthcare facility environment |
| Proximity fields from RF wireless communications equipment | IEC 61000-4-3 | See Attachment 1 | Professional healthcare facility environment |
| Electrical fast transient / burst | IEC 61000-4-4 | ±2.0 kV power supply 100 kHz repetition frequency | Professional healthcare facility environment |
| Surges Line-to-line | IEC 61000-4-5 | ±0.5, ±1 kV | Professional healthcare facility environment |
| Surges Line-to-ground | IEC 61000-4-5 | ±0.5, ±1, ±2kV | Professional healthcare facility environment |
| Conducted disturbances Induced by RF fields | IEC 61000-4-6 | 3V 0,5 MHz – 80 MHz 6V in ISM bands Between 0,15MHz and 80 MHz 80% AM at 1 kHz | Professional healthcare facility environment |
| RATED power frequency magnetic fields | IEC 61000-4-8 | 30 A/m 50 Hz or 60Hz | Professional healthcare facility environment |
| Voltage dips | IEC 61000-4-11 | 0% UT : 0.5 cycle At 0°, 45°, 90°, 135°, 180°, 225°, 270°and 315° | Professional healthcare facility environment |
| | | 0% UT: 1 cycle and 70% UT: 25/30 cycles Single phase: at 0° | Professional healthcare facility environment |
| Voltage interruptions | IEC 61000-4-11 | 0% UT: 250/300 cycle | Professional healthcare facility environment |

Attachment 1.

**Test specifications for ENCLOSURE PORT IMMUNITY to
RF wireless communications equipment**

| Test Frequency (MHz) | Band ^{a)} (MHz) | Service ^{a)} | Modulation ^{b)} | Maximum Power (W) | Distance (M) | IMMUNITY TEST LEVEL (V/m) |
|---------------------------------|-------------------------------------|--|--|------------------------------|-------------------------|--------------------------------------|
| 385 | 380- 390 | TETRA 400 | Pulse modulation ^{b)} 18Hz | 1,8 | 0,3 | 27 |
| 450 | 430- 470 | GMRS 460, FRS 460 | FM ^{c)} ± 5kHz deviation 1 kHz sine | 2 | 0,3 | 28 |
| 710 | 704- 787 | LTE Band 13, 17 | Pulse modulation ^{b)} 217 Hz | 0,2 | 0,3 | 9 |
| 745 | | | | | | |
| 780 | | | | | | |
| 810 | 800- 960 | GSM 800/900, TETRA 800, iDEN 820, CDMA 850, LTE Band 5 | Pulse modulation ^{b)} 18 Hz | 2 | 0,3 | 28 |
| 870 | | | | | | |
| 930 | | | | | | |
| 1 720 | 1 700- 1 990 | GSM 1800; CDMA 1900; GSM 1900; DECT; LTE Band 1, 3, 4, 25; UMTS | Pulse modulation ^{b)} 217 Hz | 2 | 0,3 | 28 |
| 1 845 | | | | | | |
| 1 970 | | | | | | |
| 2 450 | 2 400- 2 570 | Bluetooth, WLAN, 802. 11 b/g/n, RFID 2450, LTE Band 7 | Pulse modulation ^{b)} 217 Hz | 2 | 0,3 | 28 |
| 5 240 | 5 100- 5 800 | WLAN 802.11 a/n | Pulse modulation ^{b)} 217 Hz | 0,2 | 0,3 | 9 |
| 5 500 | | | | | | |
| 5 785 | | | | | | |

NOTE If necessary to achieve the IMMUNITY TEST LEVEL, the distance between the transmitting antenna and the ME EQUIPMENT or ME SYSTEM may be reduced to 1 m. The 1 m test distance is permitted by IEC 61000-4-3.

^{a)} For some services, only the uplink frequencies are included.

^{b)} The carrier shall be modulated using a 50 % duty cycle square wave signal.

^{c)} As an alternative to FM modulation, 50 % pulse modulation at 18 Hz may be used because while it does not represent actual modulation, it would be worst case.

Basic performance: none

Intended behavior

Cable length
Main tube: about 1.5m
Foot control: about 700 mm

Three-way Syringe Output: Water and Spray: 30mL / 15sec., minimum
Vacuum Syringe Performance: Volume: 90 L / min., minimum
It depends on the vacuum motor.
(Reference value)
Volume: 140 L / min., minimum
(with EV-12 Type II)

10.4 EC DECLARATION OF CONFORMITY

J. MORITA TOKYO MFG. CORP.

7129 Komuro Ina-machi Kitaadachi-gun Saitama 362-0806 Japan

EC DECLARATION OF CONFORMITY

We

J. MORITA TOKYO MFG. CORP.

7129 Komuro Ina-machi Kitaadachi-gun Saitama 362-0806 Japan

declare under exclusively responsibility, that the product:

| | |
|------------------------------|------------------------------|
| Kind of product | Dental treatment unit |
| Name | signo T500 |
| Model | TUA60, TUA70 |
| Medical product class | IIa (Rule 9) |

is in compliance with the European Directives :

| |
|---|
| COUNCIL DIRECTIVE 93/42/EEC of 14 June 1993 concerning medical devices |
| Annex I of 2006/42/EC “Directive of the European Parliament and of the Council of 17 May 2006 on machinery” |
| 2011/65/EU “Directive of the European Parliament and of the Council of 8 June 2011 on the restriction of the use of certain hazardous substances in electrical and electronic equipment” |
| 2014/53/EU “Directive of the European Parliament and of the Council of 16 April 2014 on the harmonisation of the laws of the Member States relating to the making available on the market of radio equipment and repealing Directive 1999/5/EC” |

The technical documentation as submitted and full compliance with the standards listed below proves the conformity with the essential requirements of the above-mentioned EC Directive.

EN 1041:2008+A1:2013, EN 1639:2009, EN 1640:2009, EN ISO 10993-1:2009+AC:2010,
EN ISO14971:2012, EN ISO15223-1:2016, EN ISO17664:2017,
EN 60601-1:2006+A12:2014, EN 60601-1-2:2015, EN 60601-1-6:2010
EN 62304:2006 /A1:2015, EN 62366:2008, EN 50581:2012
EN 300 328 V2.1.1

The compliance with requirements of Annex II has been proven by the following certificate.

Name of the Certificate : EC Certificate Full Quality Assurance System
Directive 93/42/EEC on Medical Devices (MDD), Annex II excluding (4)
Registration No: G1 093092 0010
Notified Body (NB): TÜV SÜD Product Service GmbH
NB identification No.: 0123
Validity period: 2024-05-26

EU authorized representative : J. MORITA EUROPE GMBH
Justus-von-Liebig-Str. 27b 63128 Dietzenbach
Germany

Signature:

Saitama, Japan, 21. APR. 2021

(Place, date)

Phone:+81-48-723-2621

Fax :+81-48-723-2622



Eiji Esaki
Managing Director

Diagnostic and Imaging Equipment



Treatment Units



Handpieces and Instruments



Endodontic Systems



Laser Equipment



Laboratory Devices



Educational and Training Systems



Auxiliaries



Authorized representative in the European Community

EC REP J. MORITA EUROPE GMBH

Justus-von-Liebig-Str. 27b 63128 Dietzenbach Germany Tel: +49 6074 836 0

Manufacturer

J. MORITA TOKYO MFG. CORP.

Main Factory 7129 komuro, Ina-machi, Kitaadachi-gun, Saitama Japan 362-0806 Tel: +81. 48. 723 2621

Morita Global Site: www.morita.com

More Infos about Products: www.dental-plaza.com

Please note that specifications and appearance may change without prior notice for product improvement purposes.

The company name and product names mentioned are trademarks, or registered trademarks of J. MORITA CORP. and J. MORITA TOKYO MFG. CORP.

As the color of the product is printed, it may differ from the actual color.

Some optional equipment is included.